

FITTING INSTRUCTION

Clamp mark in acc. with		Cables joining
ISO	PN	
1	L	Left directional lights
2	+	Rear fog lights
3	31	Ground
4	R	Right directional lights
5	58R	Right side parking lights
6	54	Stoplights
7	58L	Left side parking lights

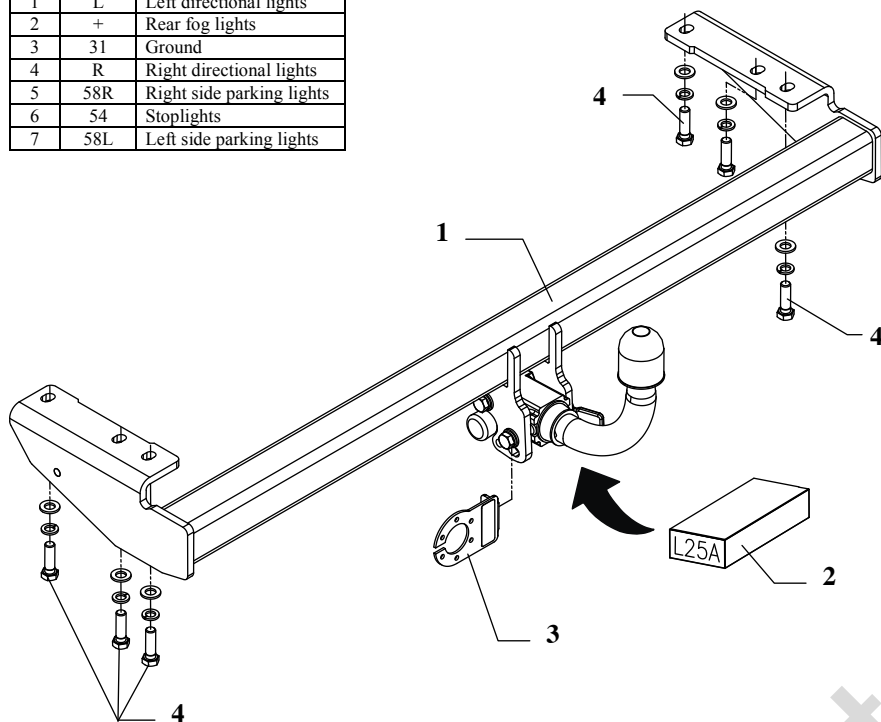

This towing hitch is designed to assembly in following cars: **VOLVO XC70 ESTATE, CROSS COUNTRY**, produced since 03.2000 till 08.2004 and since 09.2004 till 08.2007, catalogue number **L25A** and is prepared to tow trailers max total weight **2000 kg** and max vertical load **75 kg**.

From manufacturer

Thank you for buying our product. Their reliability has been confirmed in many tests. Reliability of towbar depends also on correct assembly and right operation. For this reasons we kindly ask to read carefully this instruction and apply to hints.

The towing hitch should be install in points described by a car producer.

The instruction of the assembly

1. Disassemble the bumper (drill rivets).
2. Disassemble muffler handle (twist off two bolts and drill pipe rivets from thermal shield).
3. **NOTE!** Muffler handle will be not reinstall. Thermal shield fix by rivet again.
4. On the right side disassemble original towing eye (not used any more).
5. Put the main bar of the towbar (pos. 1) to chassis members and fix it using bolts M12x40mm (pos. 4) through original holes in members.
6. Reassemble the bumper after cut out fragment according to fig. 2.

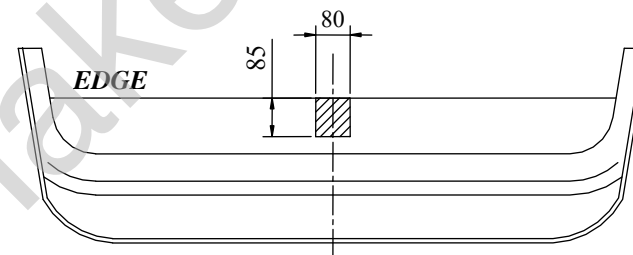

7. Fix body of the automat and according to supplied instruction. Remember about the socket plate (pos. 3).
8. Tighten all bolts according to the torque shown in the table.
9. Connect electric wires of 7-poles socket according to the instruction of the car. (Recommend to make at authorized service station)
10. Complete paint layer damaged during installation.

Torque settings for nuts and bolts (8,8):

M6 - 11 Nm	M8 - 25 Nm	M10 - 50 Nm
M12 - 87 Nm	M14 - 138 Nm	M16 - 210 Nm





NOTE

After installation of a towing hitch you should get adequate note in registration book (at authorised service station). The car should be equipped with:

- Indicators
- Tow mirrors

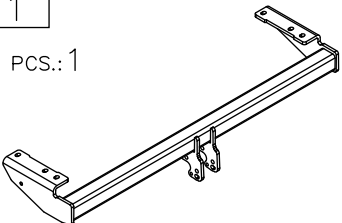
After 1000km of exploitation check all bolts and nuts. The ball of towing hitch must be always kept clear and conserve with a grease.

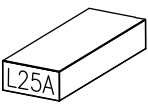
Towing hitch accessories:

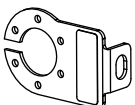
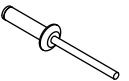
Pos. 1	Main bar PCS.: 1		Pos. 4	Bolt 8,8 B M12x40mm PCS.: 6	
			Pos. 5	Plain washer ø13mm PCS.: 6	
Pos. 2	Tow ball PCS.: 1		Pos. 6	Spring washer ø12,2mm PCS.: 6	
Pos. 3	Socket plate PCS.: 1		Pos. 7	Rivet ø4x20mm PCS.: 3	



PPUH AUTO-HAK Sp.J.

Produkcja Zaczepów Kulowych
Henryk i Zbigniew Nejman
76-200 SŁUPSK ul. Słoneczna 16K
tel/fax (059) 8-414-414; 8-414-413
E-mail: office@autohak.com.pl
www.autohak.com.pl

Towing hitch (without electrical set)

Class: **A50-X** Cat. no. **L25A**

Designed for:

Manufacturer: **VOLVO**

Model: **XC70**

Type: **ESTATE, CROSS COUNTRY**

produced since 03.2000 till 08.2004

and since 09.2004 till 08.2007

Technical data:

D-value: 10,3 kN

maximum trailer weight: **2000 kg**

maximum vertical cup load: **75 kg**

Approval number acc. to regulations EKG/ONZ 55.01: **E20 55R-01 3374**

Foreword

This towing hitch is designed according to rules of safety traffic regulations. The towing hitch is a safety component and can be install only by qualified personnel. Any alteration or conversion of the towing hitch is prohibited and would lead to cancellation of design certification. Remove insulating compound and underseal from vehicle (if present) in the area of the matting surfaces of the towing hitch. The vehicle manufacturer's specifications regarding trailer mass and max. vertical cup mass are decisive for driving whereat values for the towing hitch cannot be exceeded.

D-value formula:

$$\frac{\text{Max trailer weight [kg]} \times \text{Max vehicle weight [kg]}}{\text{Max trailer weight [kg]} + \text{Max vehicle weight [kg]}} \times \frac{9,81}{1000} = D \text{ [kN]}$$