

AUTO-HAK Sp. z o.o.

ul. Słoneczna 16K 76-200 SŁUPSK
POLAND

tel/fax +48 59 8 414 414; +48 59 8 414 413

e-mail: office@autohak.com.pl

www.autohak.com.pl

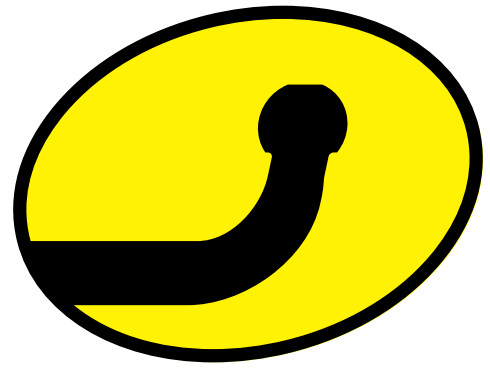

AUTO-HAK

MERCEDES M-KLASA ML
(W164), ~~AMG~~

Nr kat.

D37



07.2005 → 10.2011

e20

e20*94/20*0344*00

D

15,4 kN

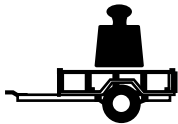

R=3500 kg

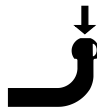

S=140



2,5h

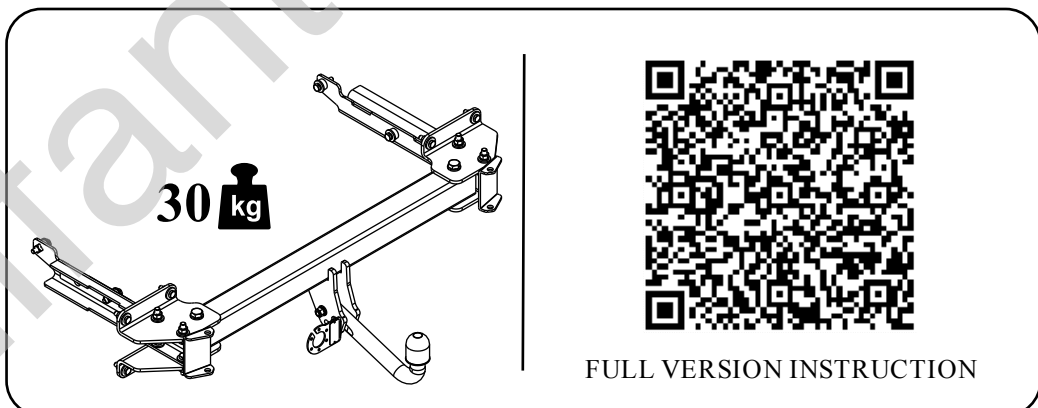

FULL VERSION INSTRUCTION



śruba	Nm	M6	M8	M10	M12	M14	M16
klasa 8.8		9,9	24	48	83	132	200
klasa 10.9		14	34	67	117	185	285









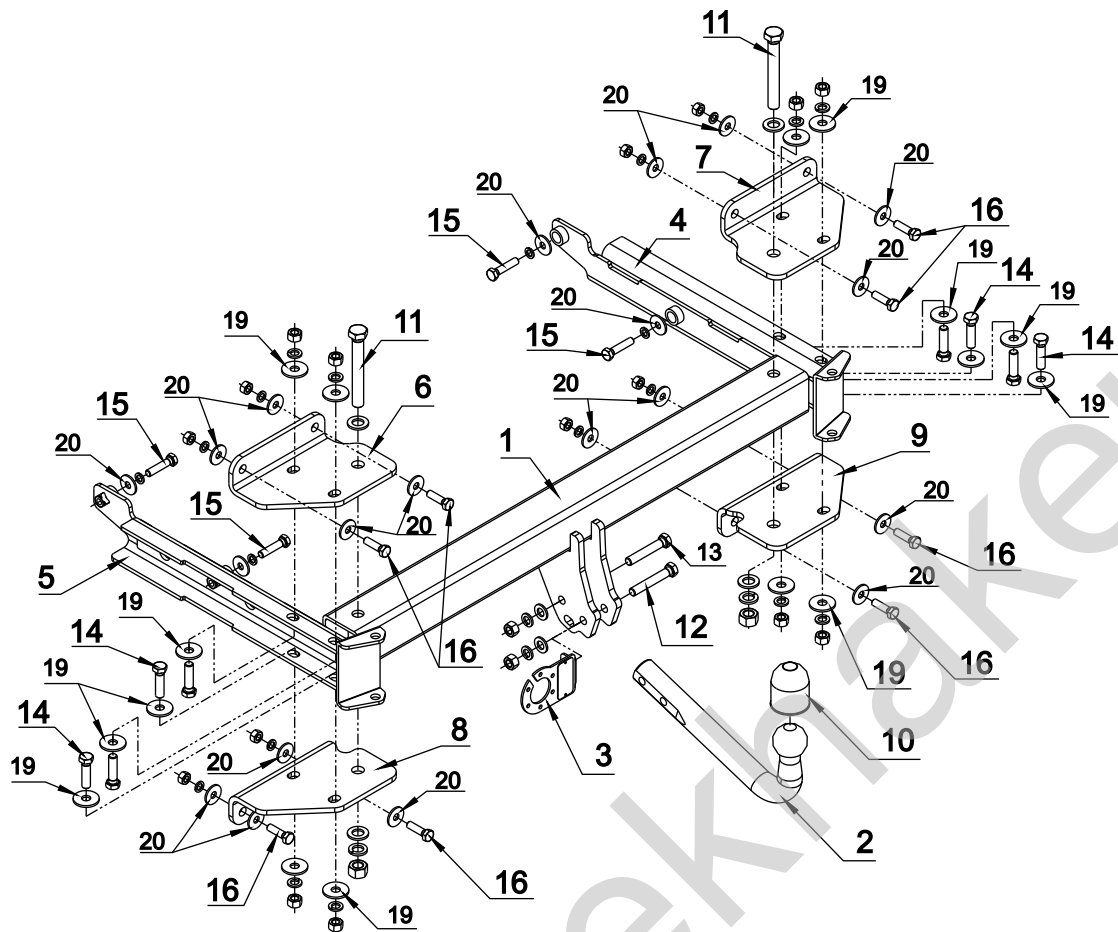

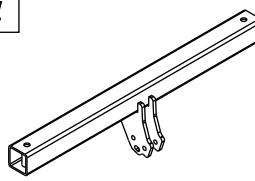









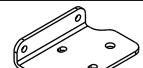







0 km



1000 km



1		x1		11 M16x120	x2
2		x1 Art.nr-KL1D37		12 M12x75	x1
3		x1 Art.nr-BL1D37		13 M12x70	x1
4		x1		14 M12x45	x8
5		x1		15 M10x45	x4
6		x1		16 M10x35	x8
7		x1		17 \varnothing 17	x4
8		x1		18 \varnothing 13	x2
9		x1		19 \varnothing 37x \varnothing 13x3 13 DIN 9021	x16
10		x1		20 \varnothing 30x \varnothing 10.5x2.5 10 DIN 9021	x20
				21 \varnothing 16.3	x2
				22 \varnothing 12.2	x10
				23 \varnothing 10.2	x12
				24 M16	x2
				25 M12	x10
				26 M10	x8
			27 		x4

F

Instructions de montage

1. Déposer les panneaux latéraux du coffre. Dégager le plancher du coffre.
2. Démonter le pare-chocs. Consulter le dessin 01.
3. Découper la partie du pare-chocs dans sa partie centrale conformément au dessin 2.
4. Démonter les supports du pare-chocs à gauche et à droite du son remplissage. Ils ne seront plus remontés. Consulter le dessin 03.
5. Placer les appuis latéraux (pos.4 et 5) dans le longeron gauche et droit et serrer de manière lâche à l'aide des vis M10x45mm (15).
6. Placer les appuis supérieurs (6 et 7) et les monter à l'aide des vis M10x35mm (16) et M12x45mm (14).
7. Placer la poutre principale de l'attelage (1) avec les appuis inférieurs (8 et 9) et serrer à l'aide des vis M16x120mm (12), M10x35mm (16) et M12x45mm (14).
8. Monter la boule de l'attelage (2) à l'aide des vis M12x75mm (12) et M12x70mm (13) avec la tôle sous la prise (3).
9. Monter le remplissage conformément au dessin 04.
10. Monter le pare-chocs.
11. Serrer toutes les vis aux couples de serrage, comme indiqué dans le tableau.
12. Connecter les câbles de la prise 7 à l'installation électrique en conformité avec les instructions d'une usine automobile (recommandé la mise en œuvre d'une station-service autorisée).
13. Remplir des pertes de peinture causées durant l'installation.

