

3 5-Türer **10/13→02/19**
3 5-door **10/13→02/19**

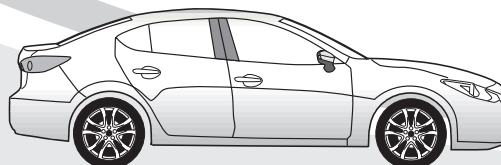

3 4-Türer **10/13→02/19**
3 4-door **10/13→02/19**

D	Einbauanleitung Elektro-Einbausatz für Anhängerkupplung / 13-polig / 12 Volt / ISO 11446
GB	Fitting instructions Electric wiring kit for towbars / 13-pin / 12 Volt / ISO 11446
F	Instructions de montage Faisceau pour attelage / 13 broches / 12 Volt / ISO 11446
I	Istruzione di montaggio Cablaggio elettrico per ganci di traino / 13 poli / 12 Volt / ISO 11446
E	Instrucciones de montaje Kits eléctricos para enganches de remolques / 13 pins / 12 Volt / ISO 11446
NL	Montagehandleiding Elektro-inbouwset voor aanhangerkoppeling / 13-polig / 12 Volt / ISO 11446

Aktuellste Version:
Latest version:



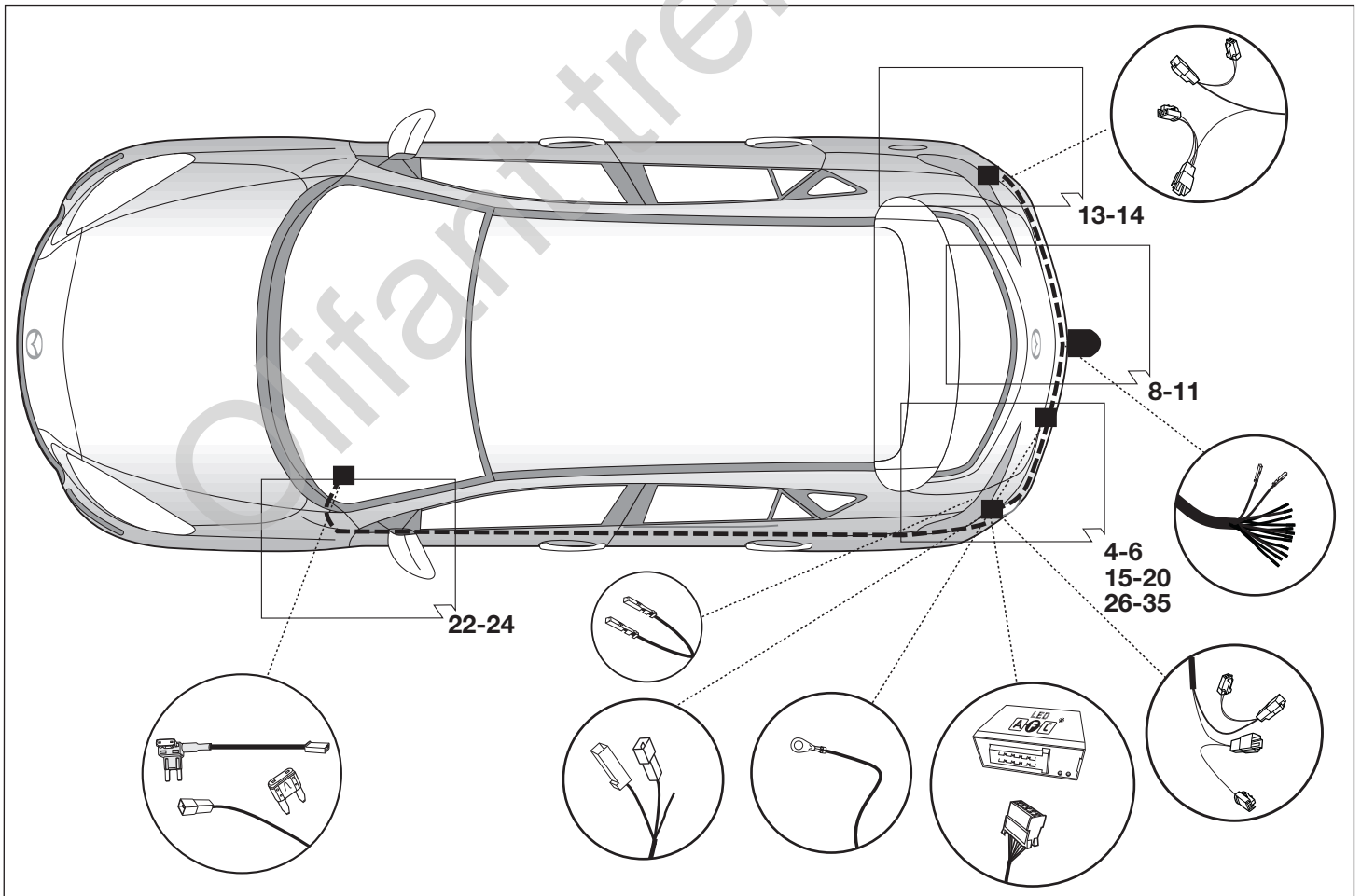
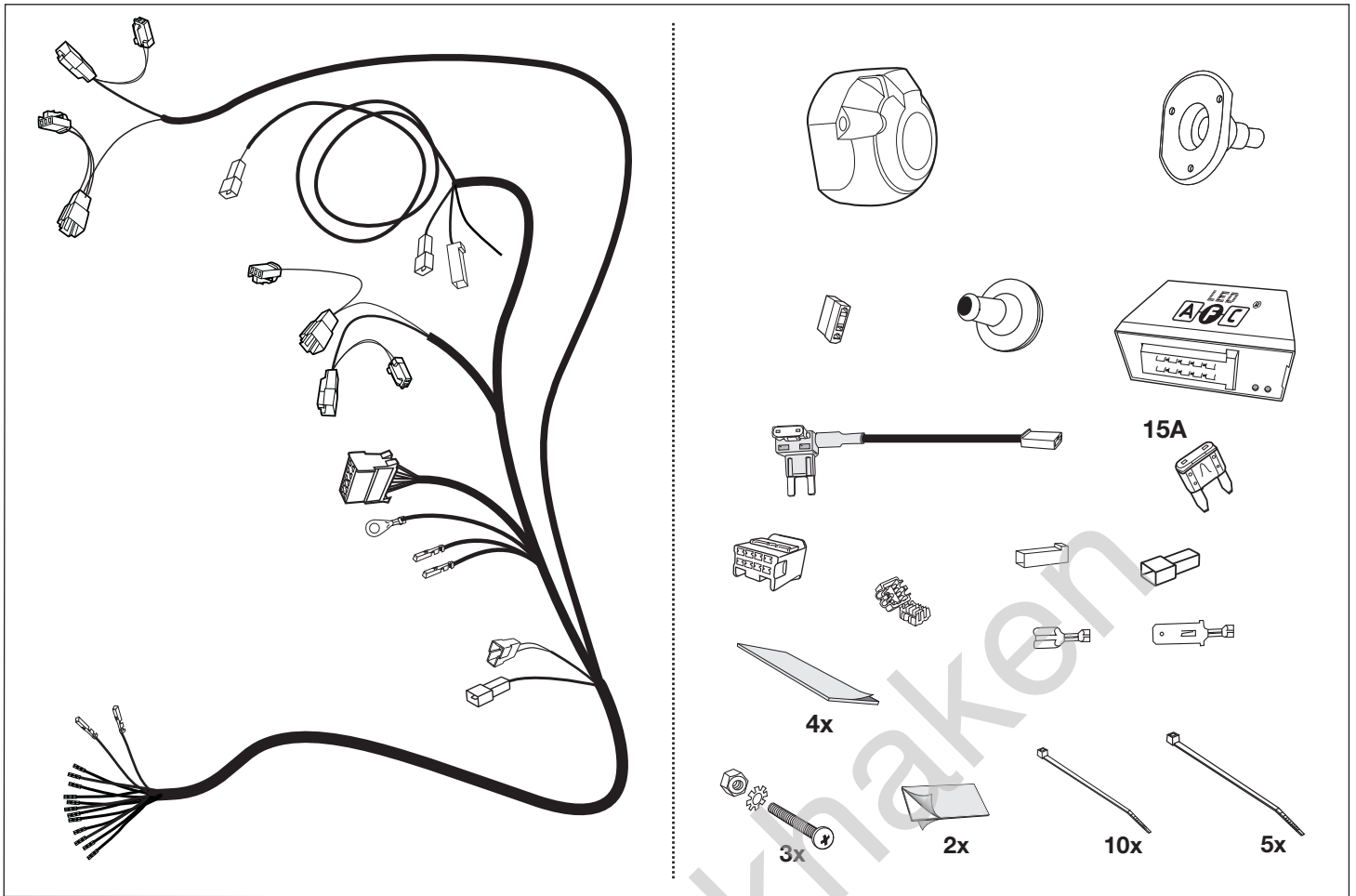

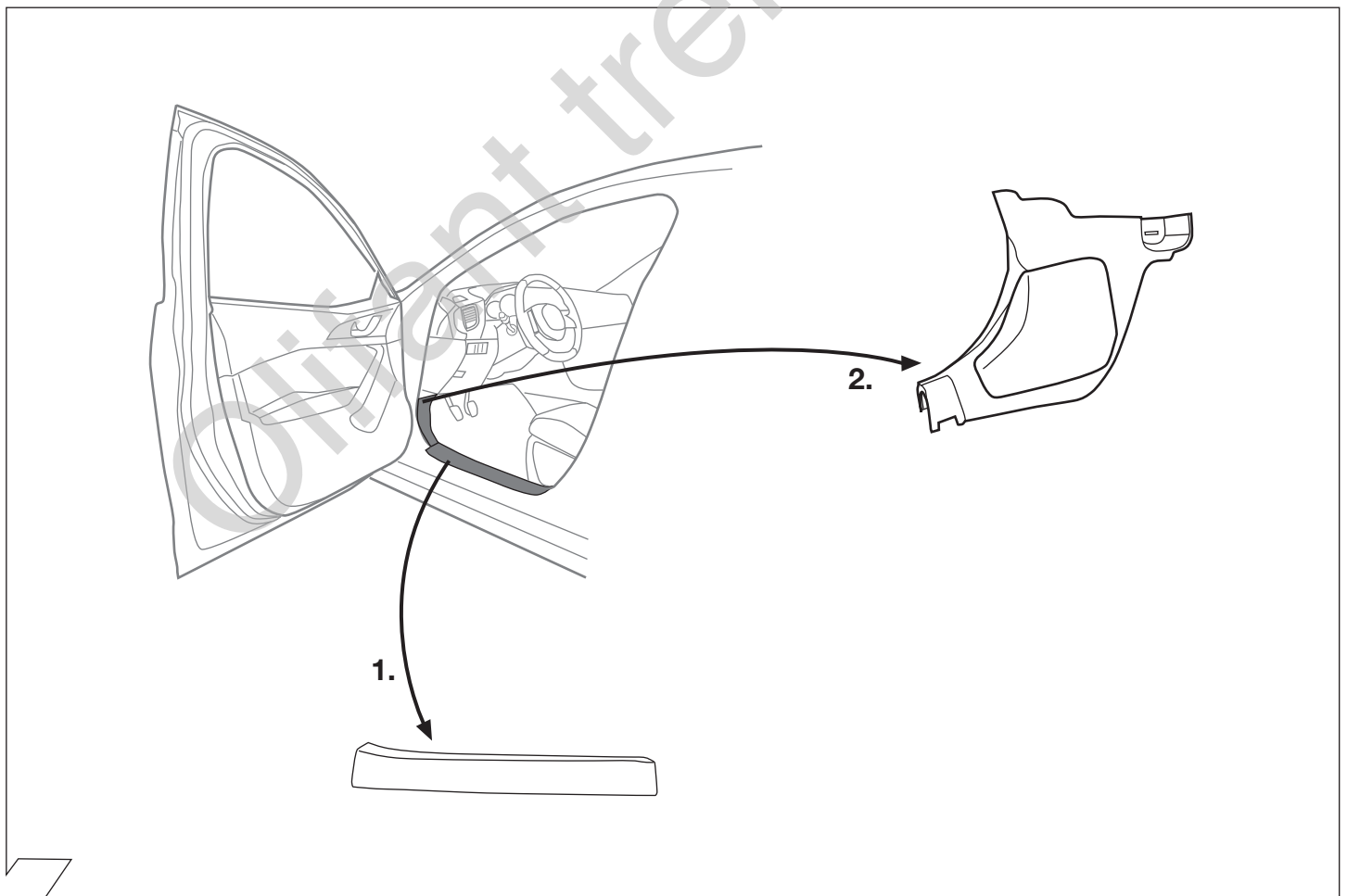
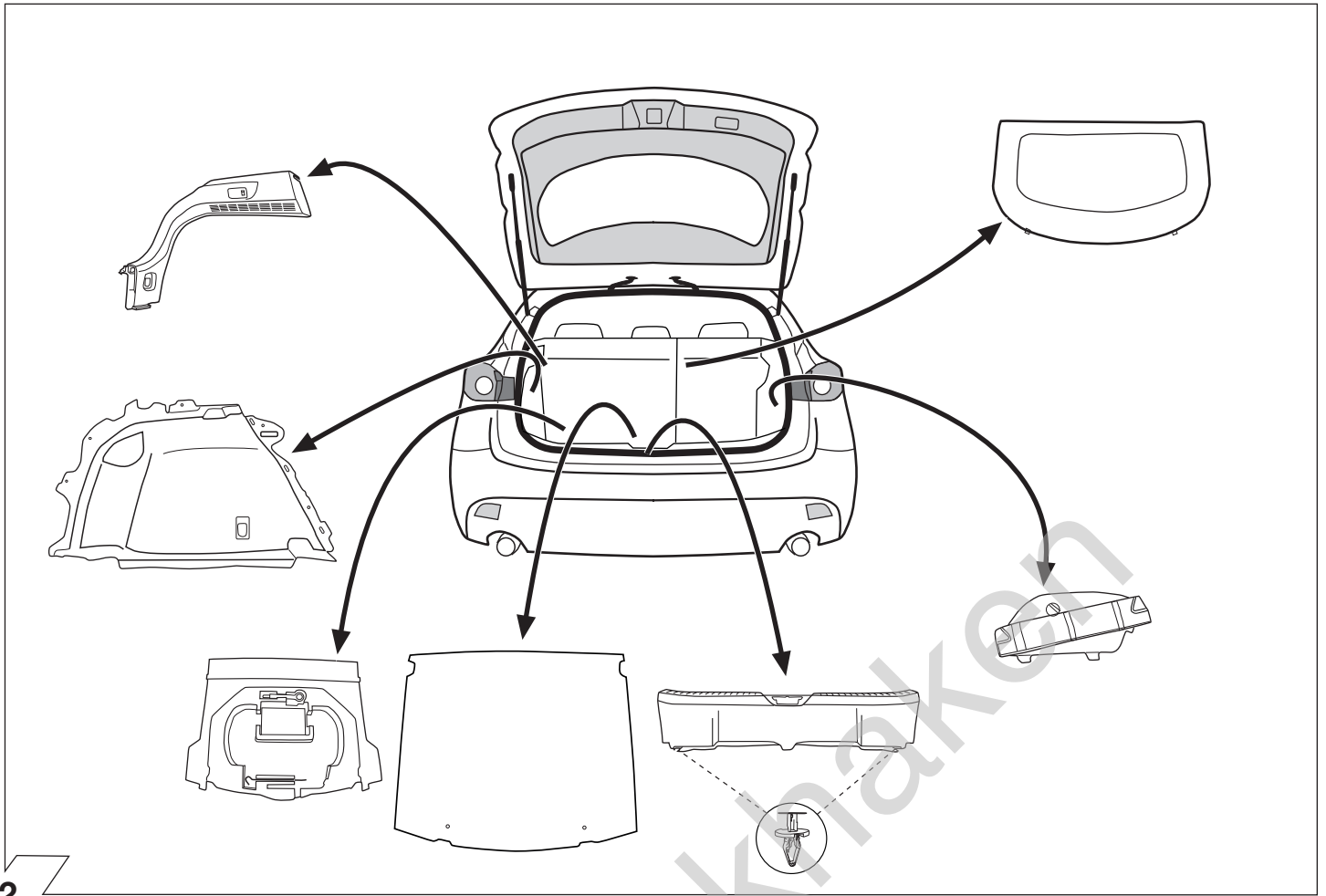

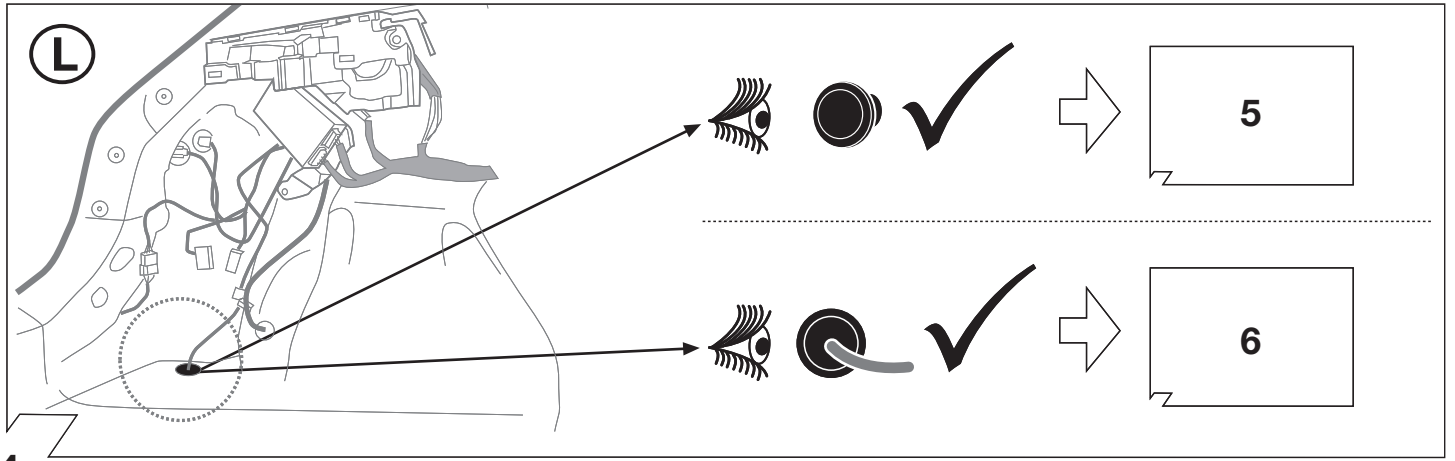

4

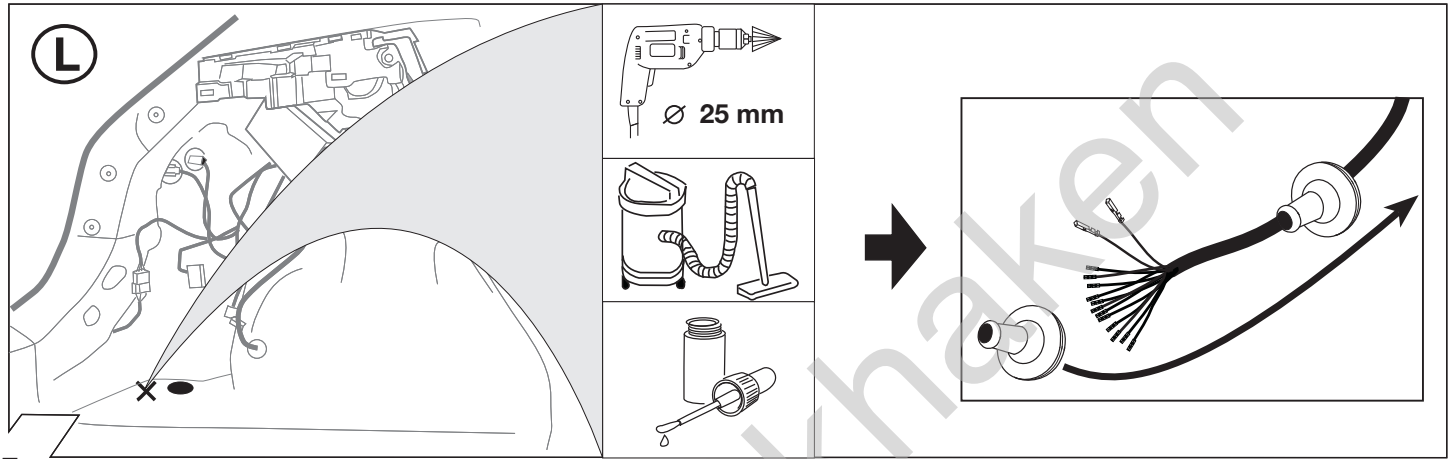

5

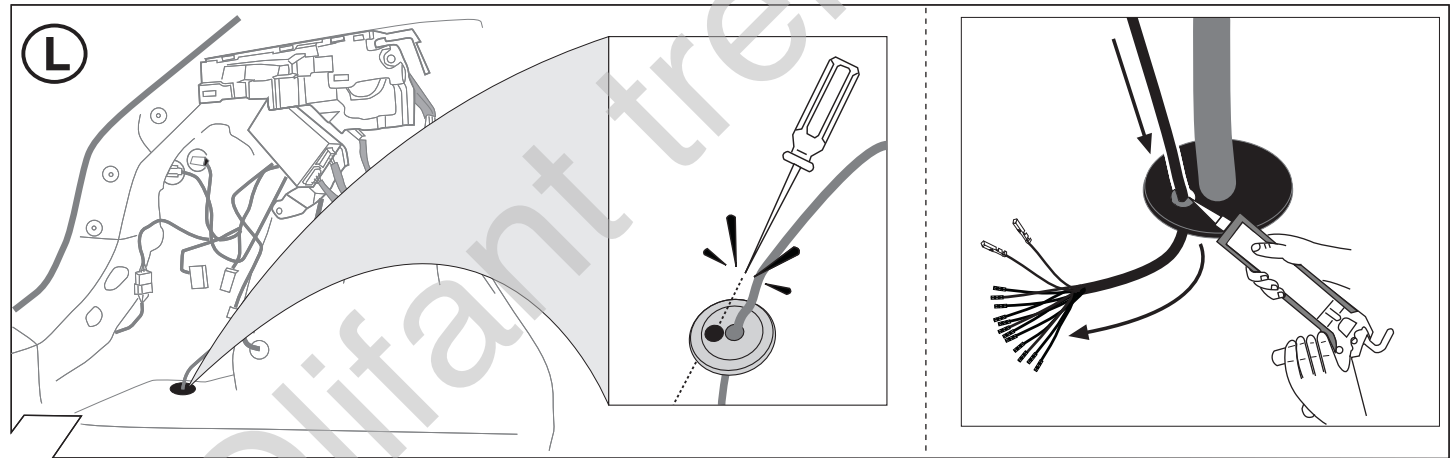

6

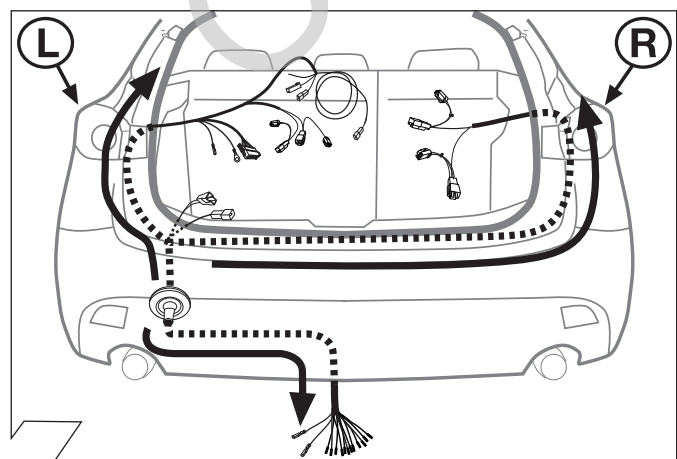

7

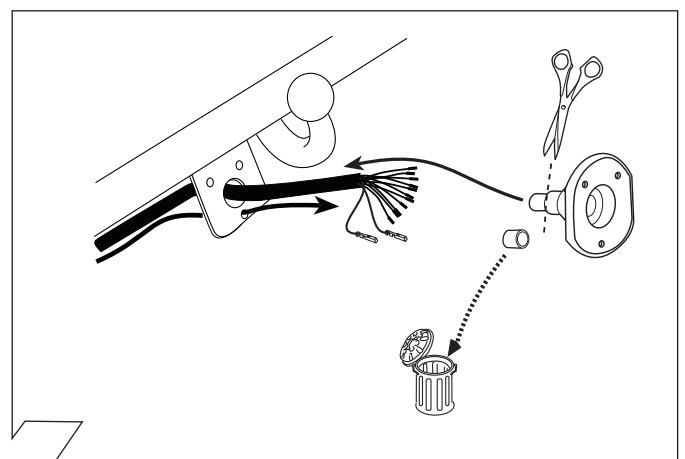

8

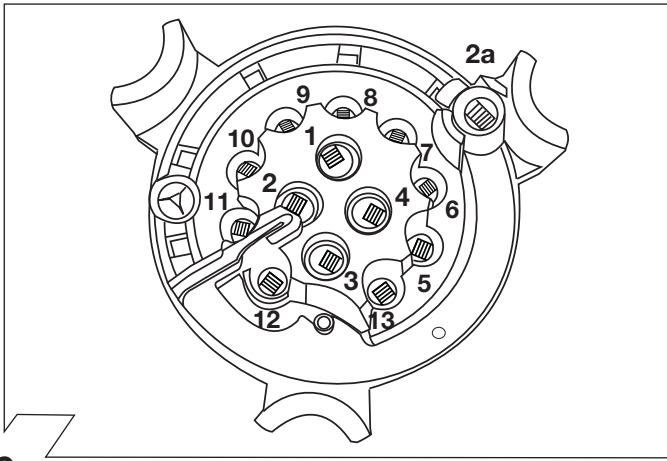

9

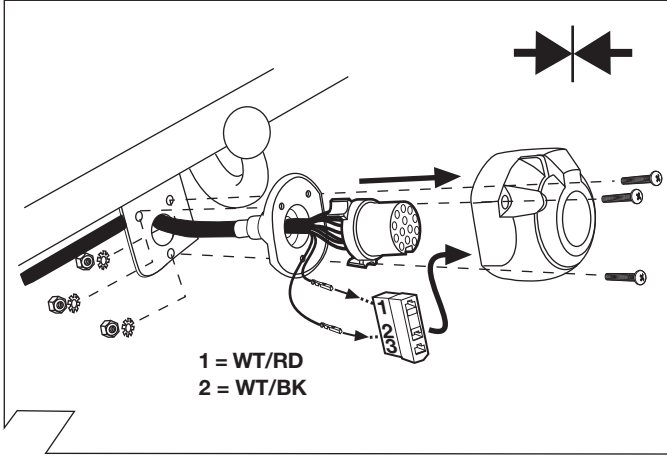

10

ISO 11446	Belegung der Steckdose / Maximale Ausgangsleistung Socket configuration / Maximum power output Correspondance des contacts de la prise / Puissance de sortie maxima Abbinamento della presa / Uscita di alimentazione massima Indeling van de steekdoos / maximaal uitgangsvermogen		
	1/L	BK/WT	21W
	2	WT	42W
	2a	BK	XXXX
	1-8	BR	XXXX
	4/R	BK/GN	21W
	5/58-R	GY/RD	52W
	6/54	BK/RD	63W
	7/58-L	GY/BK	52W
	8	BL/RD	42W
	9	RD	240W
	10	YL	180W
	11	YL/BR	XXXX
	12	XXXX	XXXX
	13	RD/BR	XXXX

11

	GB	D	E	F	I	P	NL	DK	N	S	FIN	CZ	H	PL
BK	Black	Schwarz	Negro	Noir	Nero	Preto	Zwart	Sort	Svart	Svart	Musta	Černá	Fekete	Czarny
RD	Red	Rot	Rojo	Rouge	Rosso	Vermelho	Rood	Rød	Röd	Röd	Punainen	Červená	Piros	Czerwony
GN	Green	Grün	Verde	Vert	Verde	Verde	Groen	Grøn	Grønt	Grön	Vihreä	Zelená	Zöld	Zielony
OR	Orange	Orange	Naranja	Orange	Arancione	Laranja	Oranje	Orange	Orange	Orange	Oranssi	Oranzová	Narancs	Pomarańczowy
VT	Violet	Violett	Violeta	Violet	Viola	Violeta	Violet	Violet	Fiolett	Violett	Violetti	Fialová	Ibolya	Fioletowy
PK	Pink	Pink	Pink	Rose	Rosa	Cor-de-Rosa	Paars	Pink	Pink	Rosa	Pinkki	Růžová	Rózsaszín	Różowy
BL	Blue	Blau	Azul	Bleu	Blu	Azul	Blauw	Blå	Blått	Blå	Sininen	Modrá	Kék	Niebieski
YL	Yellow	Gelb	Amarillo	Jaune	Giallo	Amarelo	Geel	Gul	Gult	Gul	Keltainen	Zlutá	Sárga	Żółty
WT	White	Weiss	Blanco	Blanc	Bianco	Branco	Wit	Hvid	Hvitt	Vit	Valkoinen	Bílá	Fehér	Biały
BR	Brown	Braun	Marrón	Brun	Marrone	Marrom	Bruin	Brun	Brunt	Brun	Ruskea	Hnědá	Barna	Brazowy
GY	Grey	Grau	Gris	Gris	Grigio	Cinzeno	Grijs	Grå	Grått	Grå	Harmaa	Sedá	Szürke	Szary

12

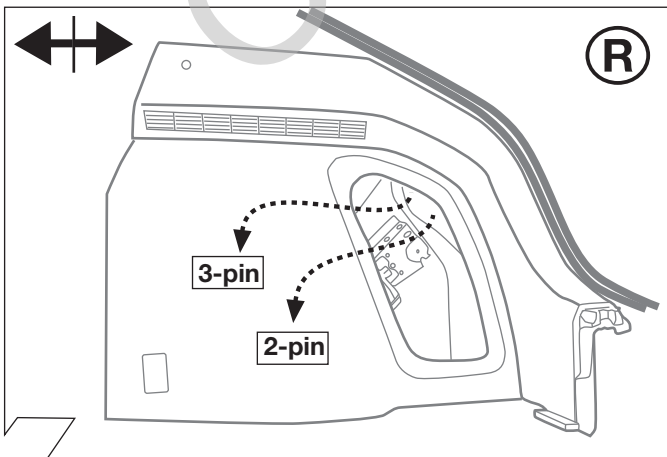

13

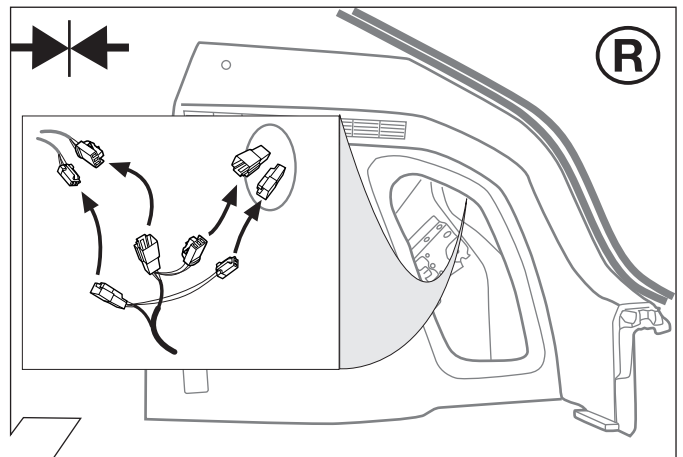

14

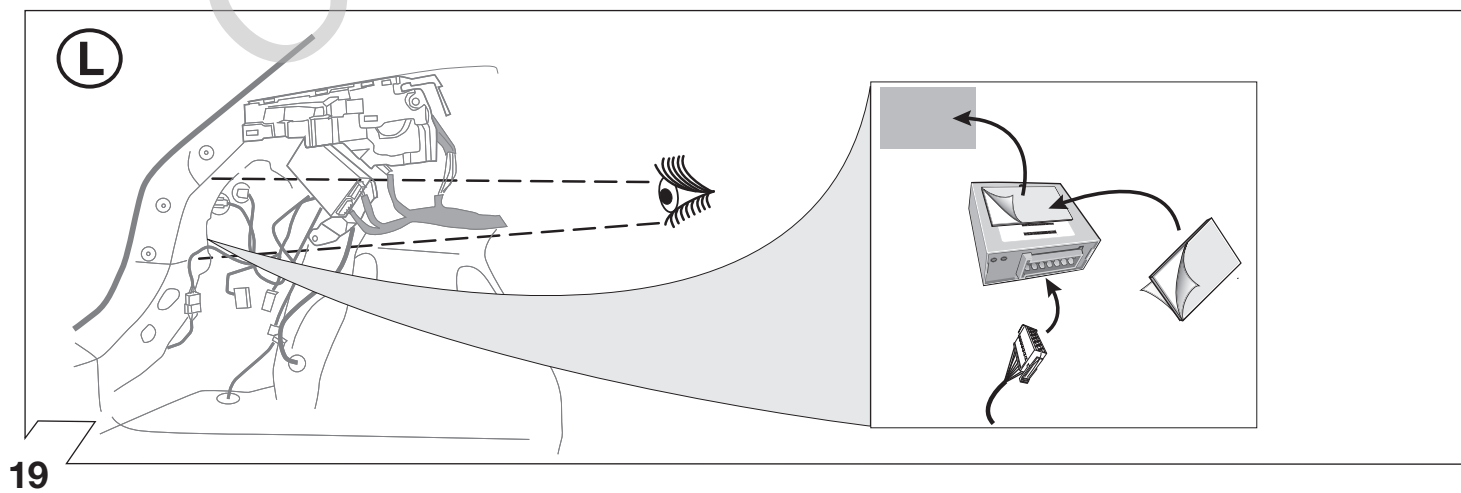
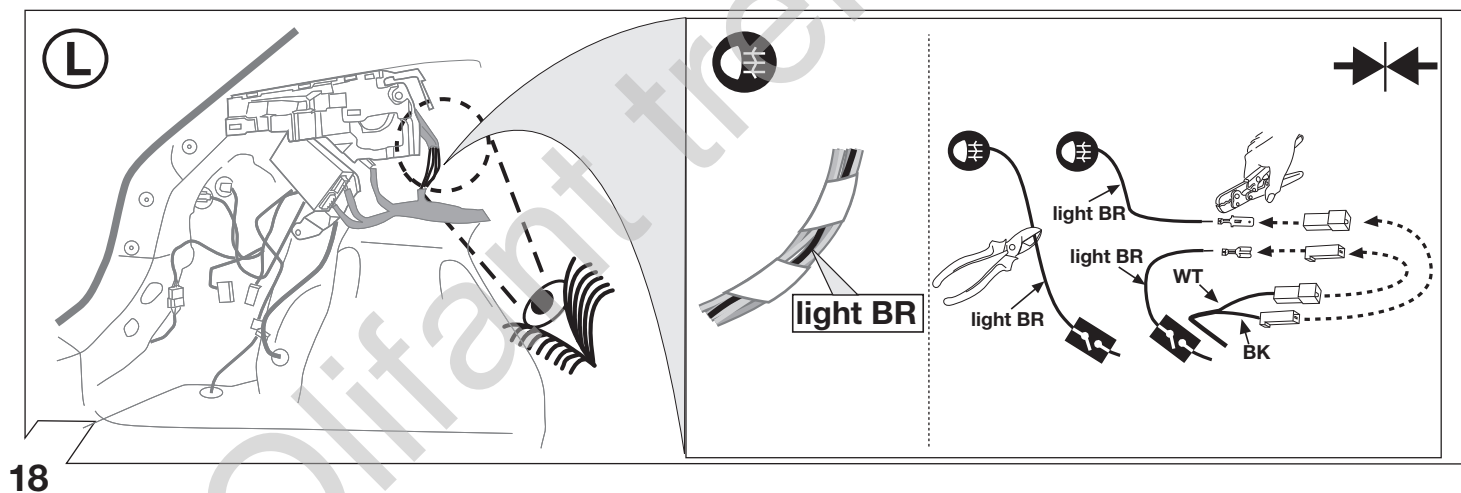
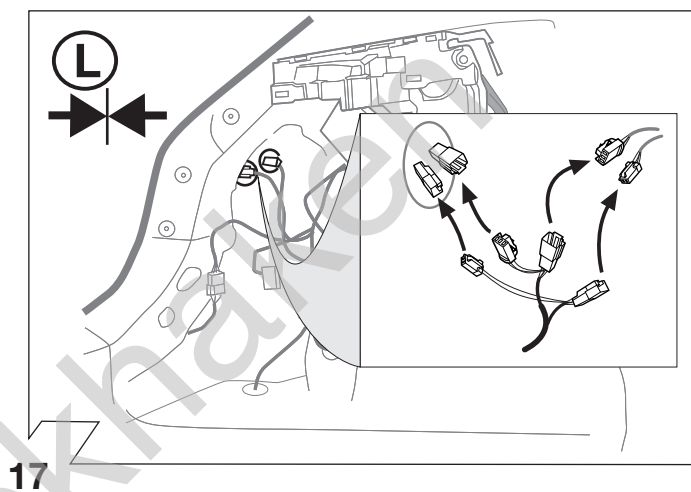
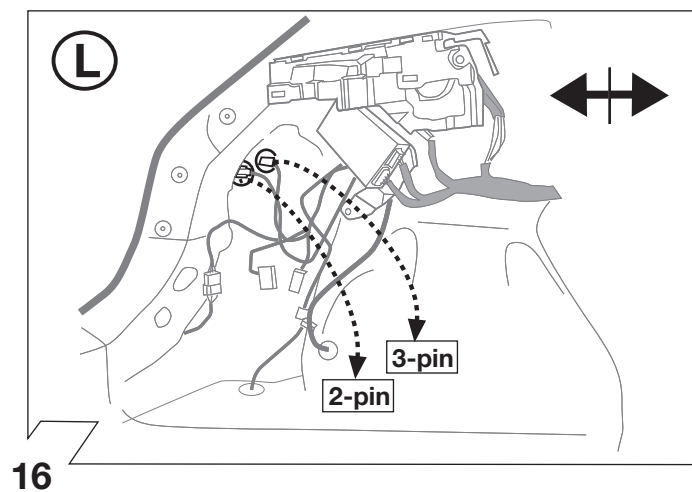
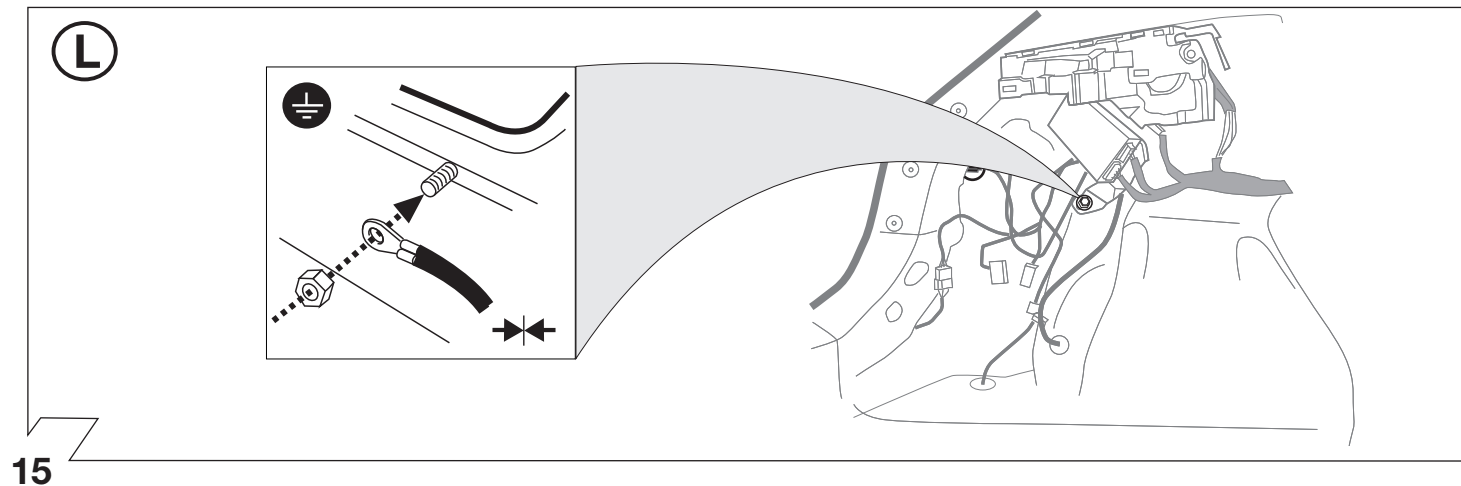

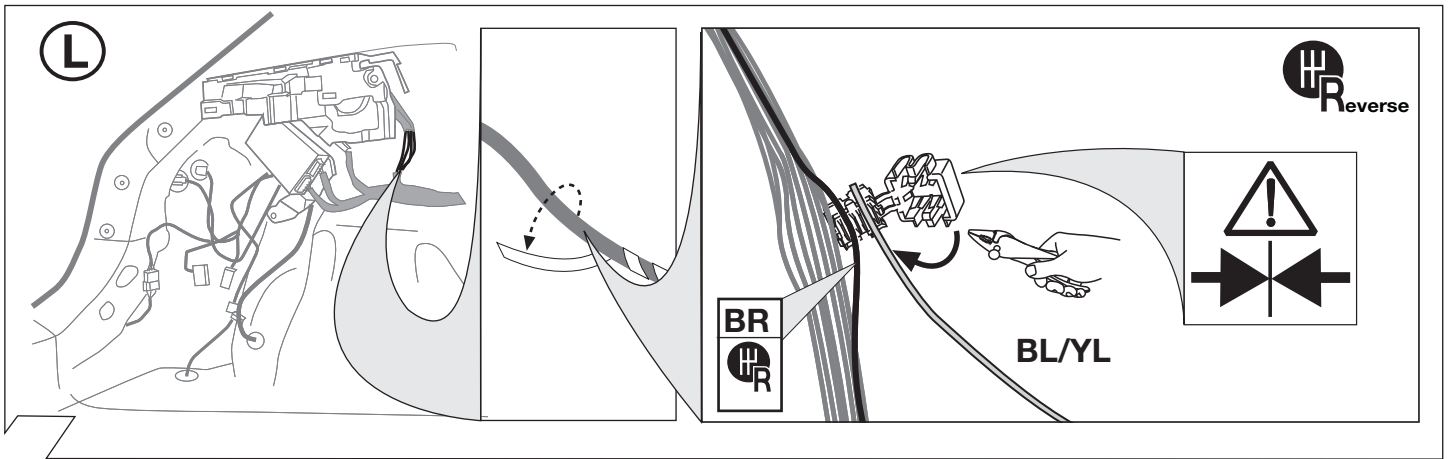

20

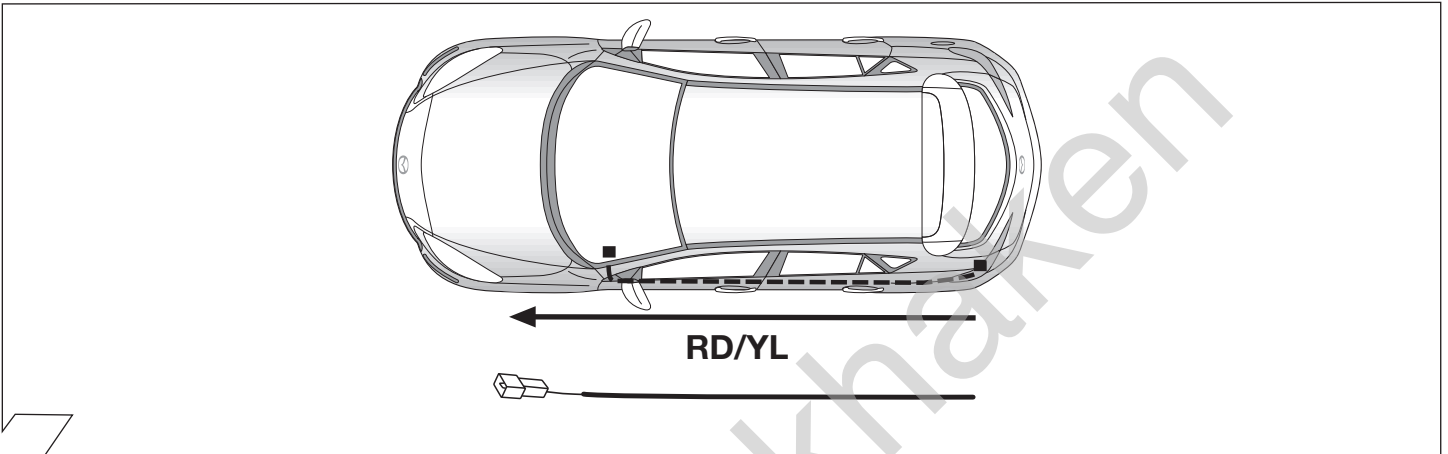

21

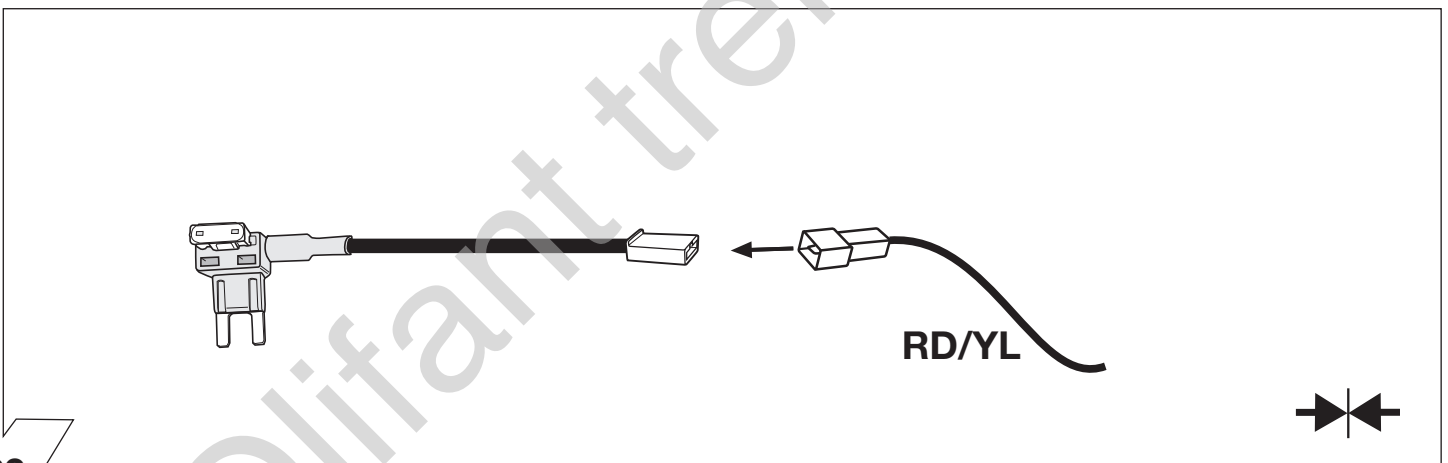

22

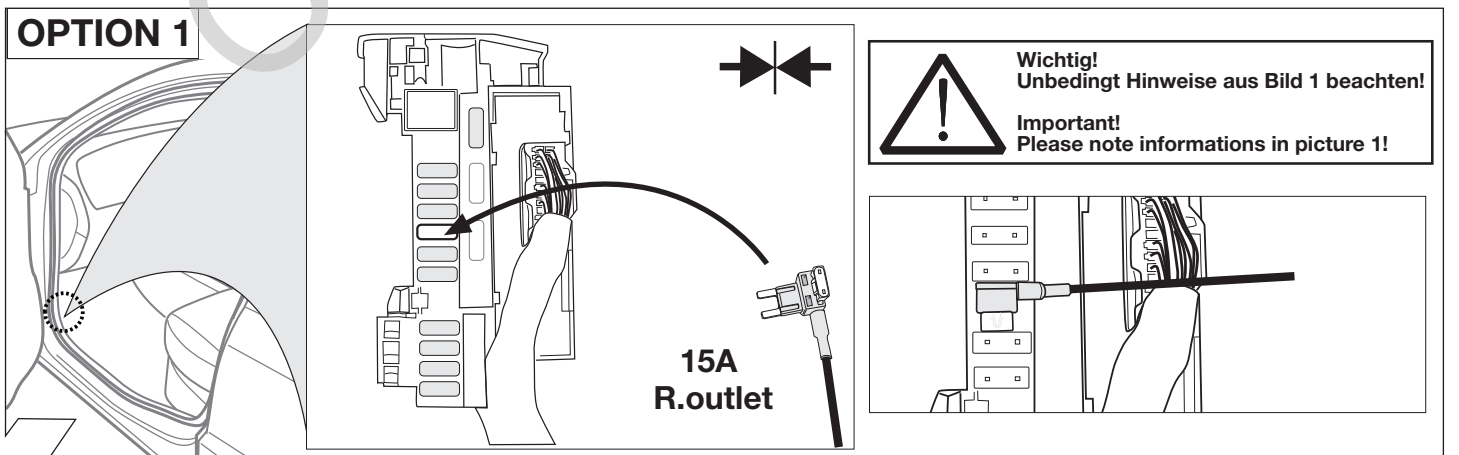

23

OPTION 2

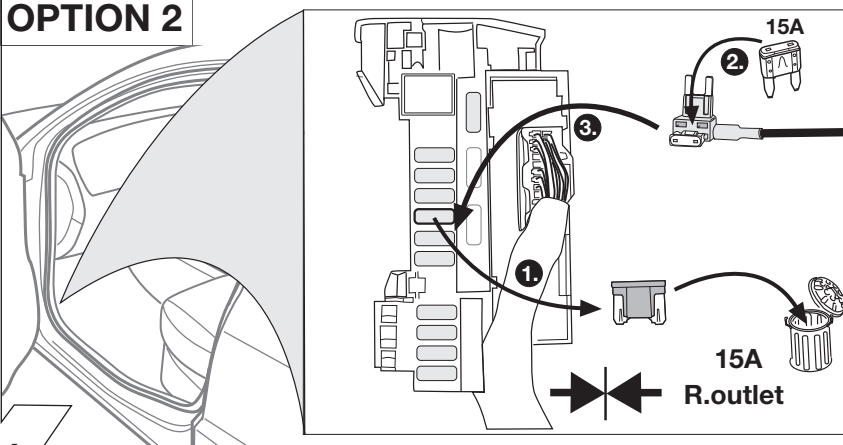

Wichtig!
Unbedingt Hinweise aus Bild 1 beachten!

Important!
Please note informations in picture 1!

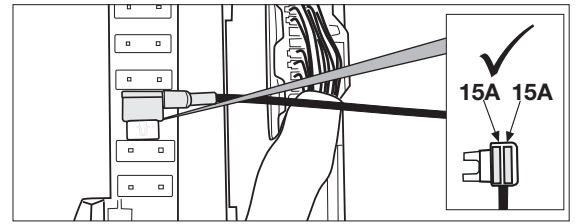

24

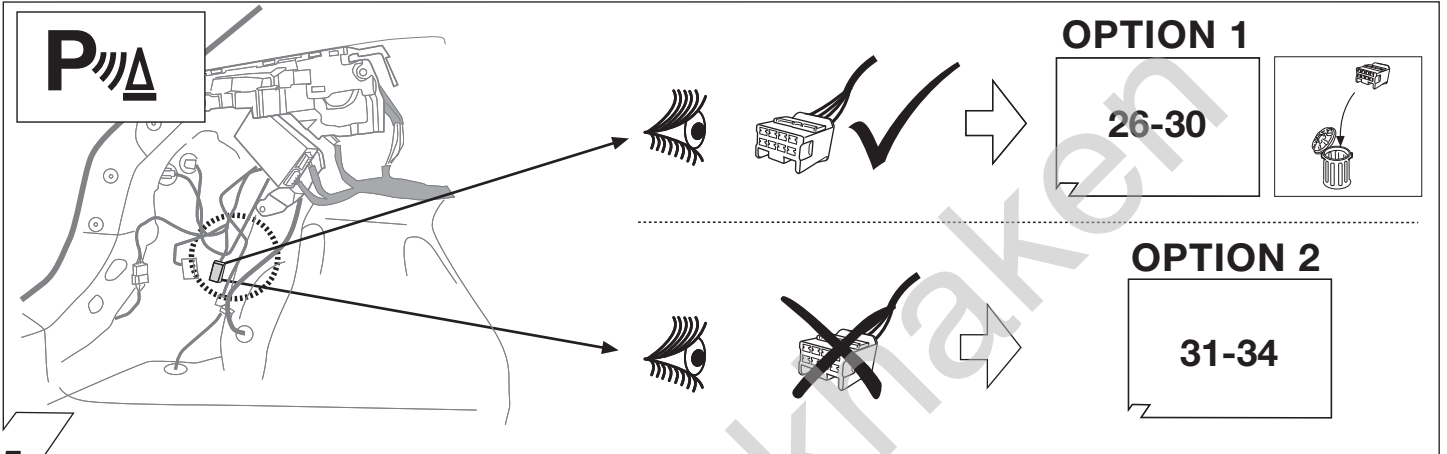

25

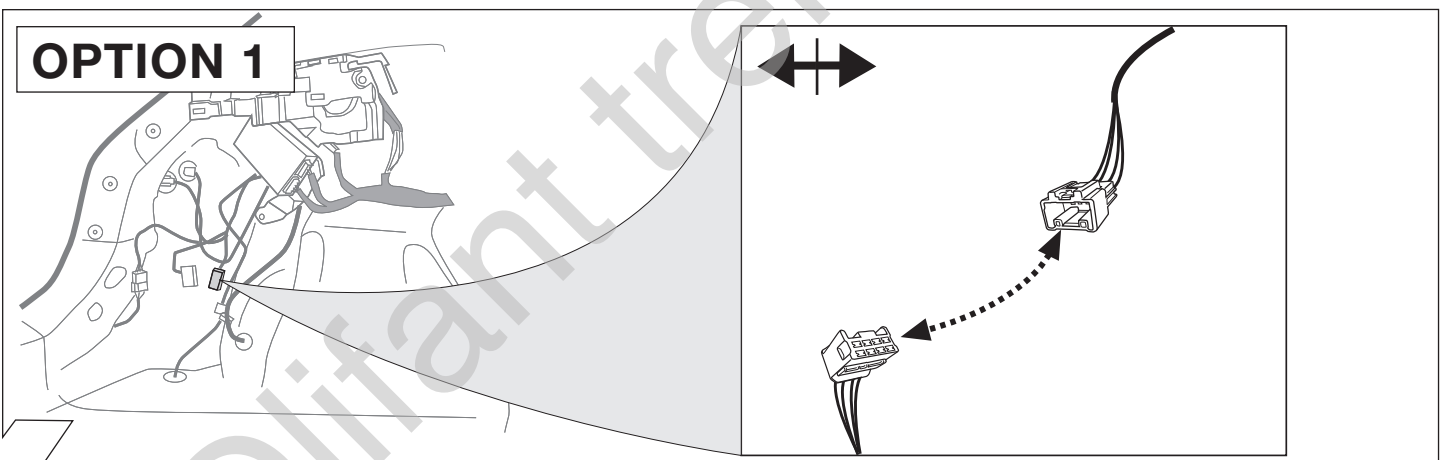

26

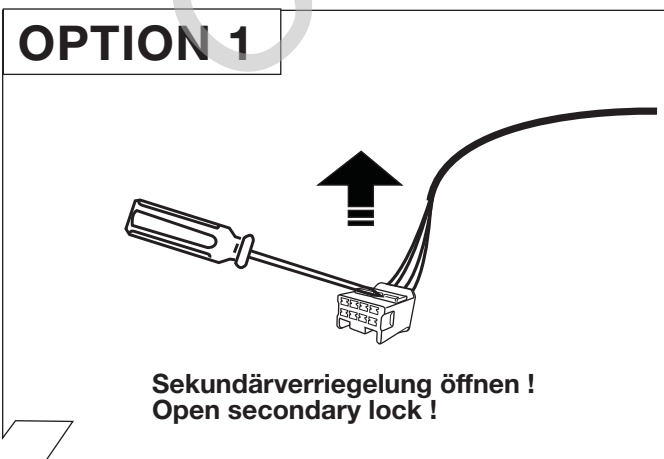

27

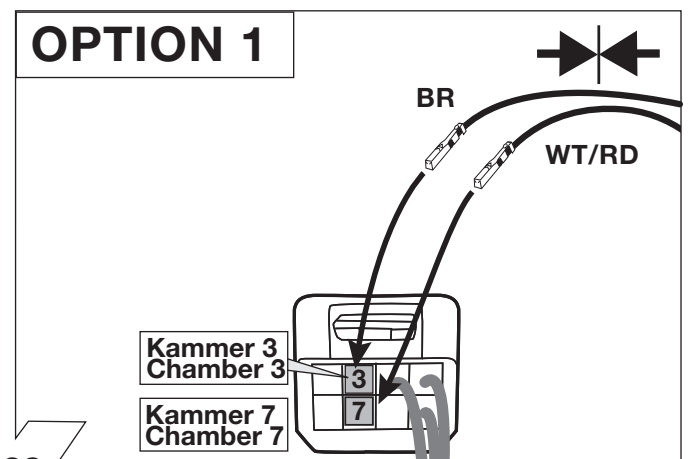

28

OPTION 1

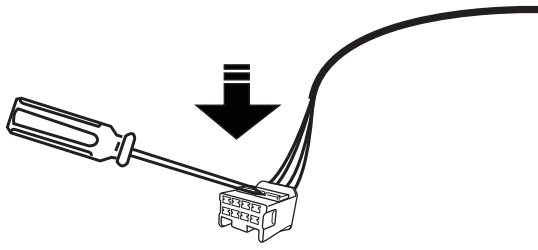

Sekundärverriegelung schliessen !
Close secondary lock !

29

OPTION 1

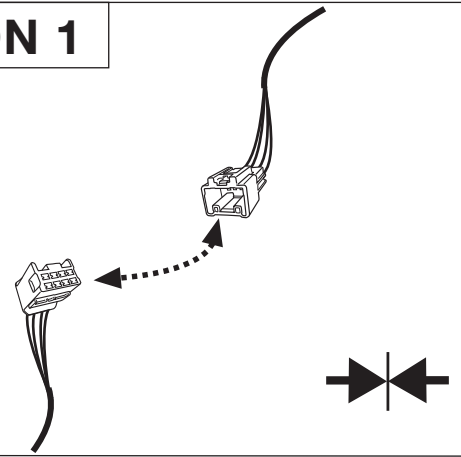

30

OPTION 2

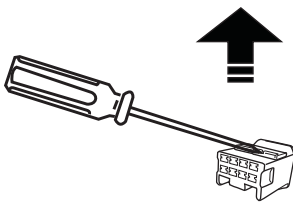

Sekundärverriegelung öffnen !
Open secondary lock !

31

OPTION 2

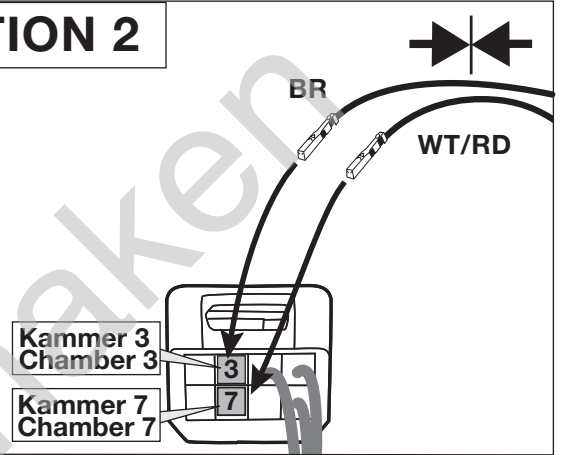

32

OPTION 2

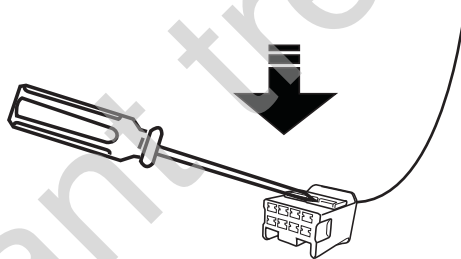

Sekundärverriegelung schliessen !
Close secondary lock !

33

OPTION 2

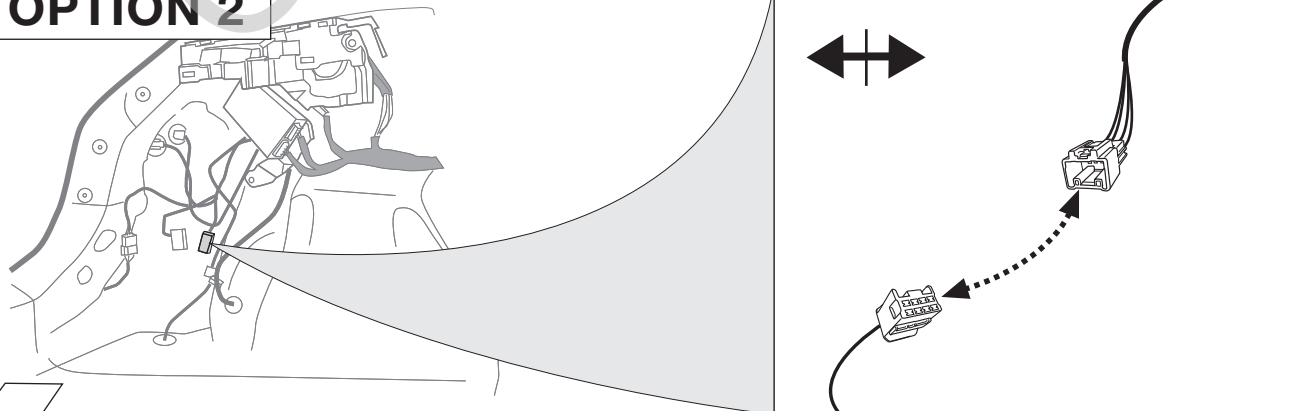

34



Fahrzeuge ohne Einparkhilfe
Vehicles without any PDC-System

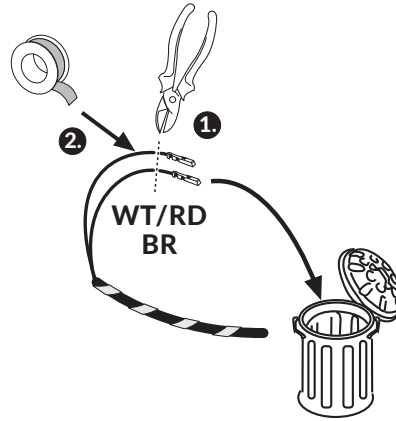

35

OPTIONAL

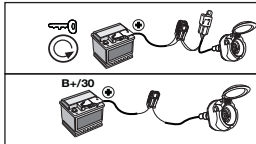
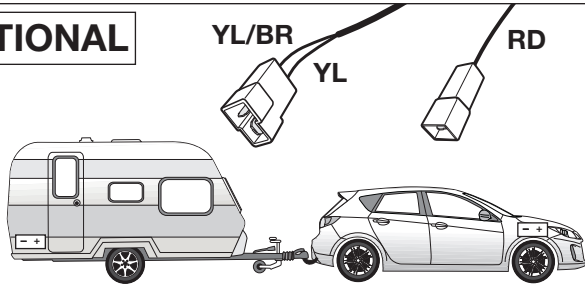

Part-no.
22400509

Part-no.
22400001

36

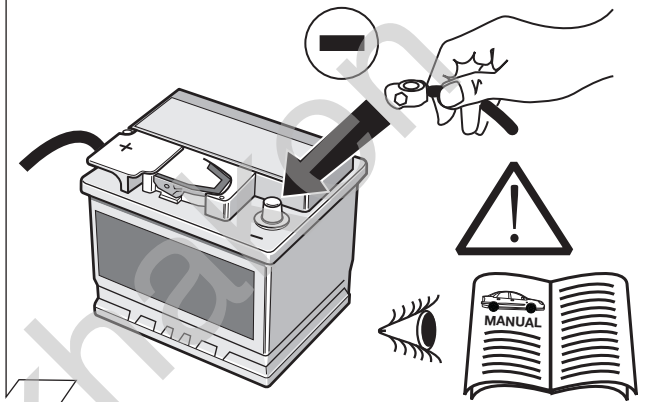

37

OPTIONAL

Trailer Simulator
for 7- and 13-pin
Sockets

Part-no.
50400522



38

39

40

Optional: Adapter socket 62930000

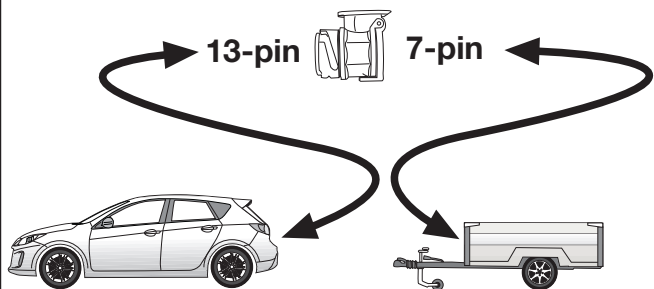

41

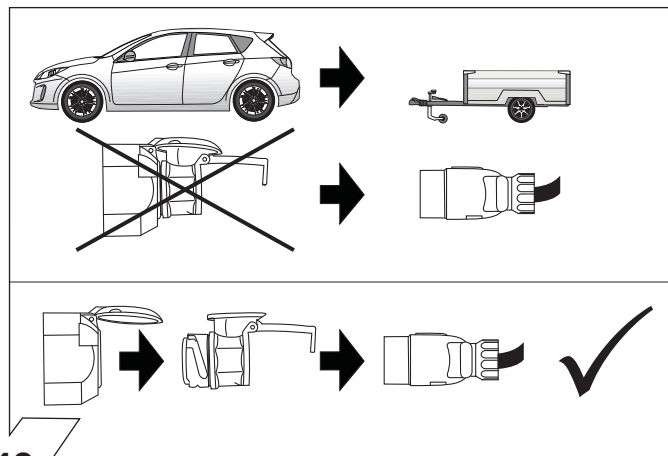

42

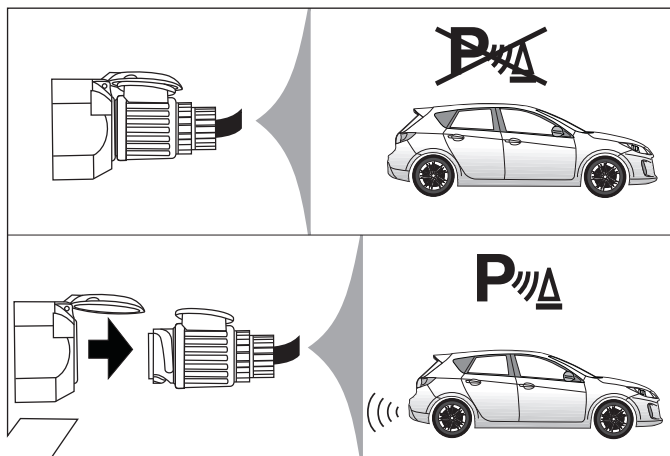

43

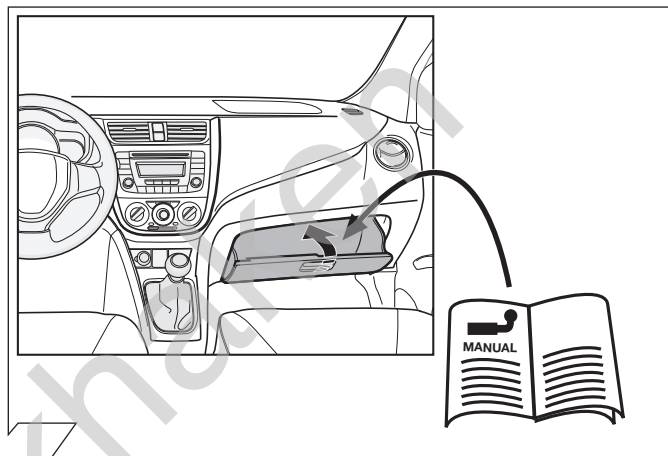

44

D Diagnosefunktion der Kontroll-LED's

GB Diagnosis function of control LEDs

F Fonction diagnostic des LED de contrôle

I Funzione di diagnostica dei LED di controllo

E Función de diagnóstico de los LEDs de control

NL Diagnosefunctie van de controle-LED's

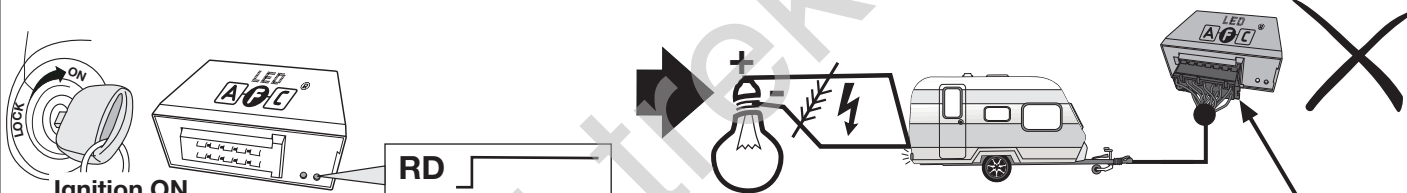
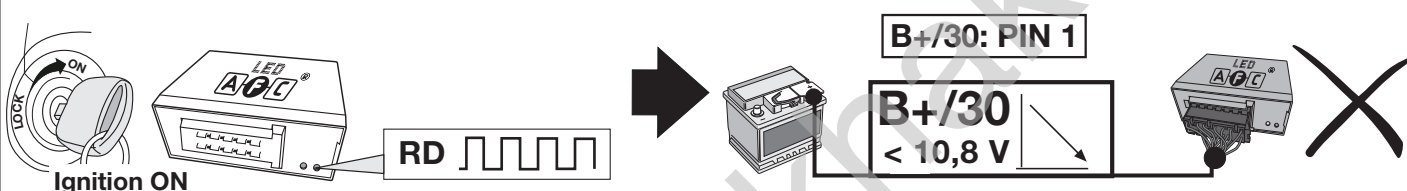
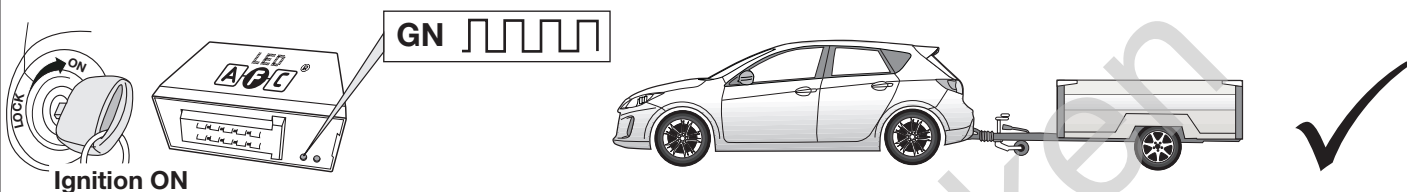
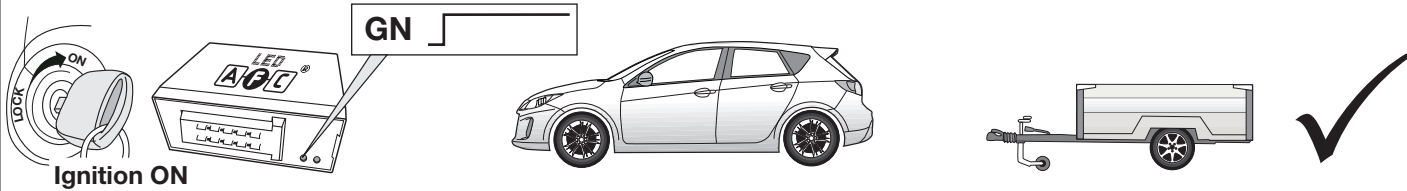
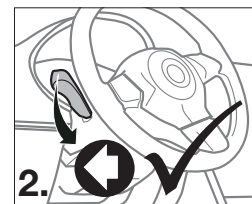
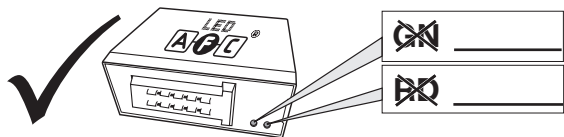

Kurzschluss/Short circuit fault on PIN 7, 8 oder/or 10

