

Freemont

08/12→

D

Elektro-Einbausatz für Anhängerkupplung / 13-polig / 12 Volt / ISO 11446

Einbauanleitung

GB

Electric wiring kit for towbars / 13-pin / 12 Volt / ISO 11446

Fitting instructions

F

Faisceau électrique pour crochet d'attelage / 13 broches / 12 Volt / ISO 11446

Instructions de montage

I

Cablaggio elettrico per ganci di traino / 13 poli / 12 Volt / ISO 11446

Istruzione di montaggio

E

Kits eléctricos para enganches de remolques / 13 pins / 12 Volt / ISO 11446

Instrucciones de montaje

NL

Elektro-inbouwset voor aanhangerkoppeling / 13-polig / 12 Volt / ISO 11446

Montagehandleiding

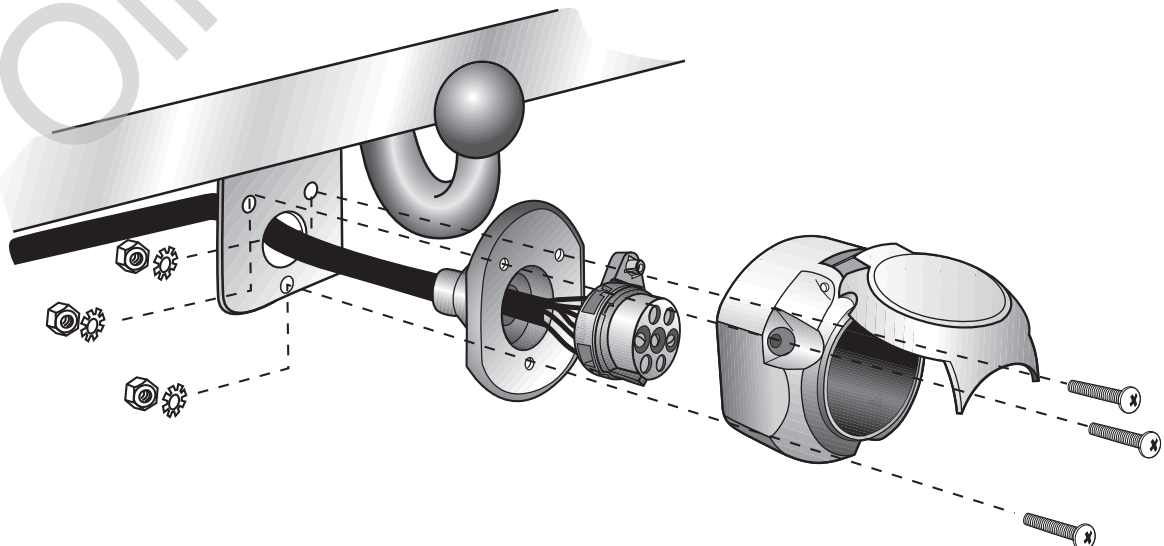

a

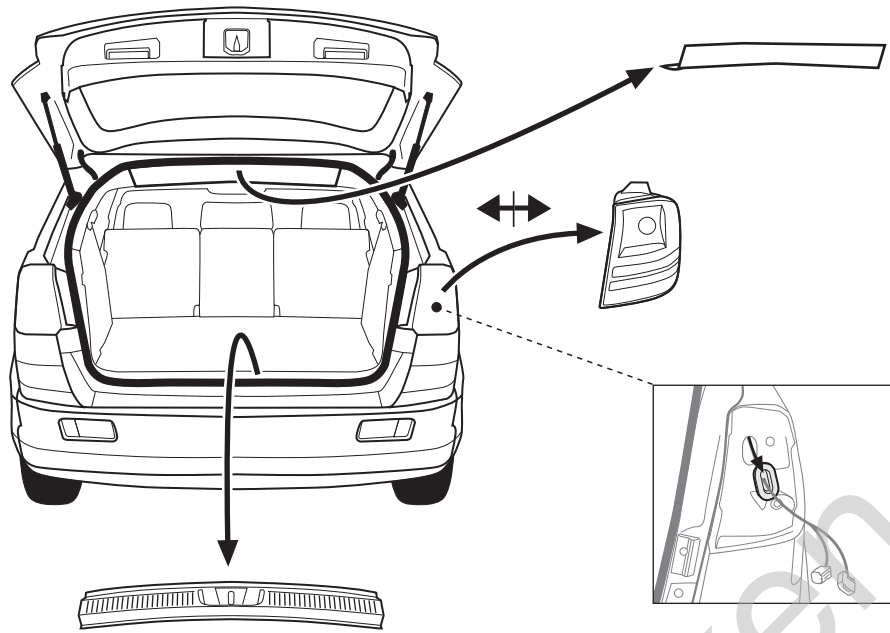

b

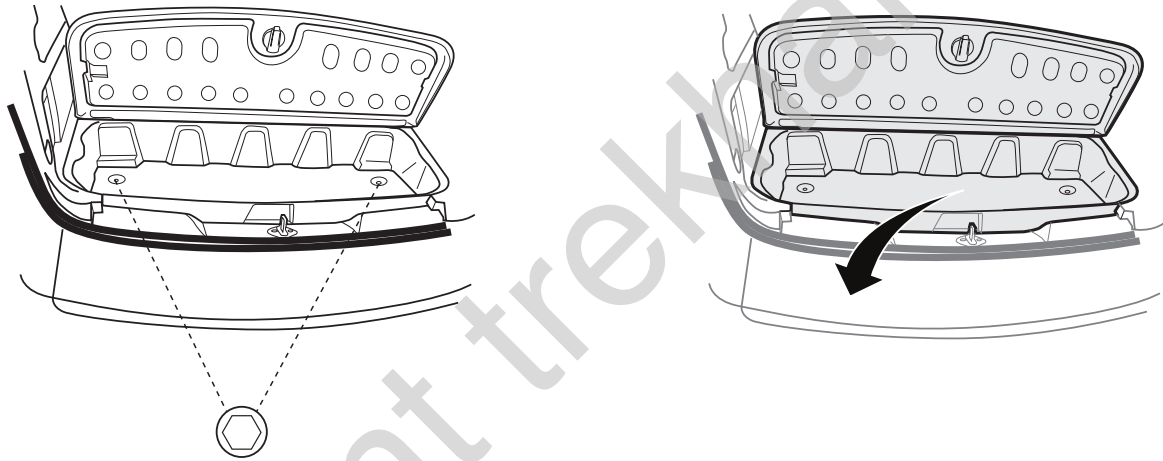

c

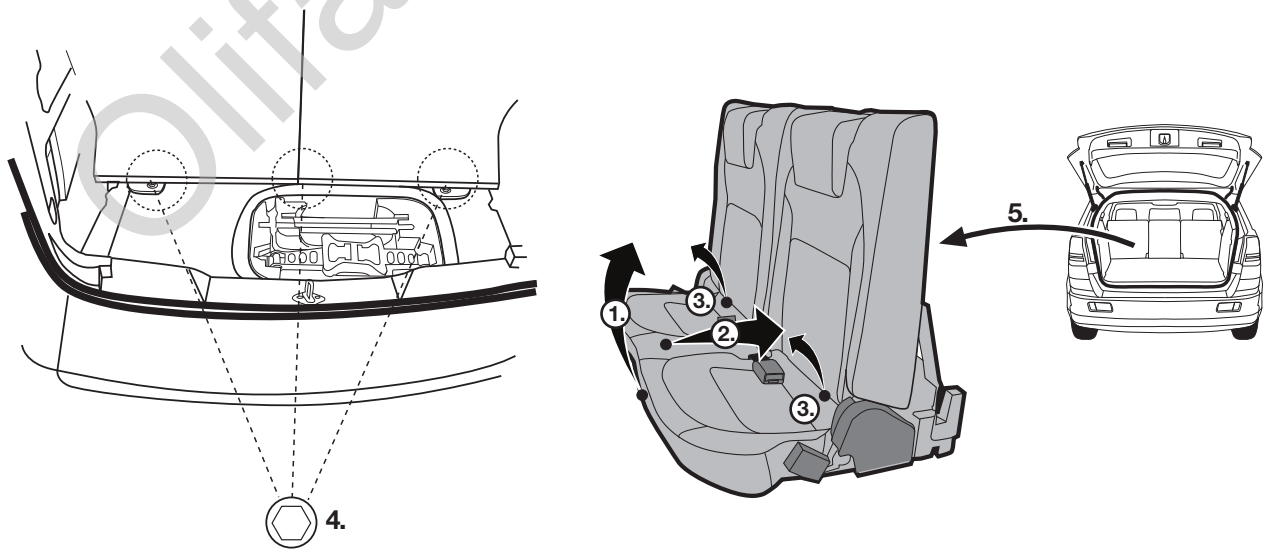

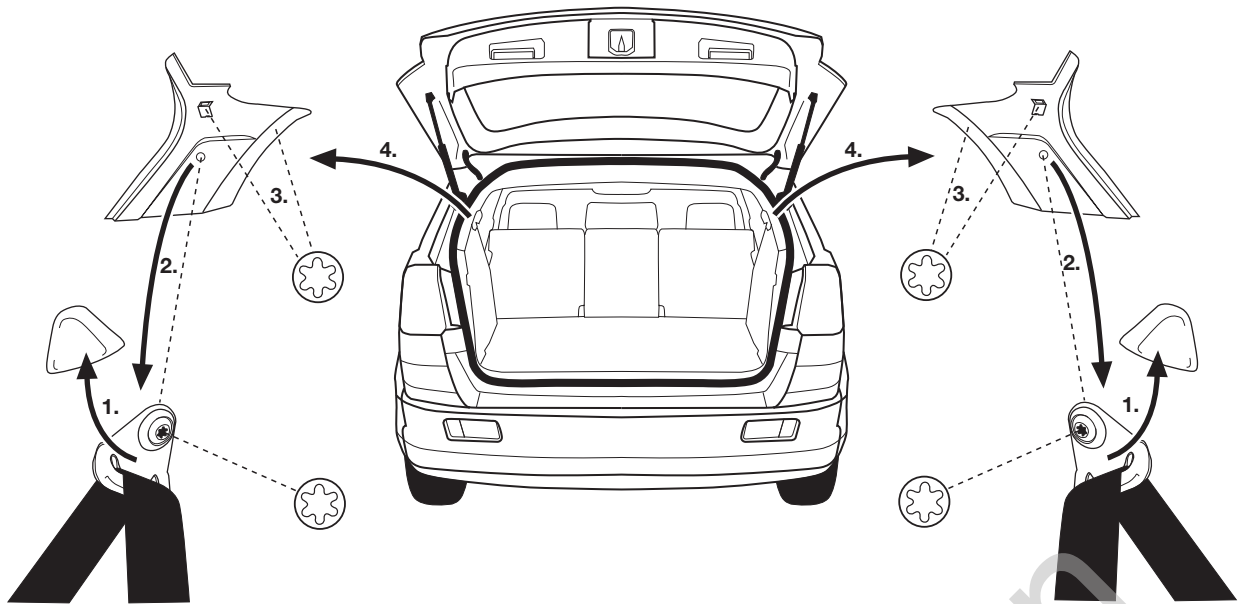
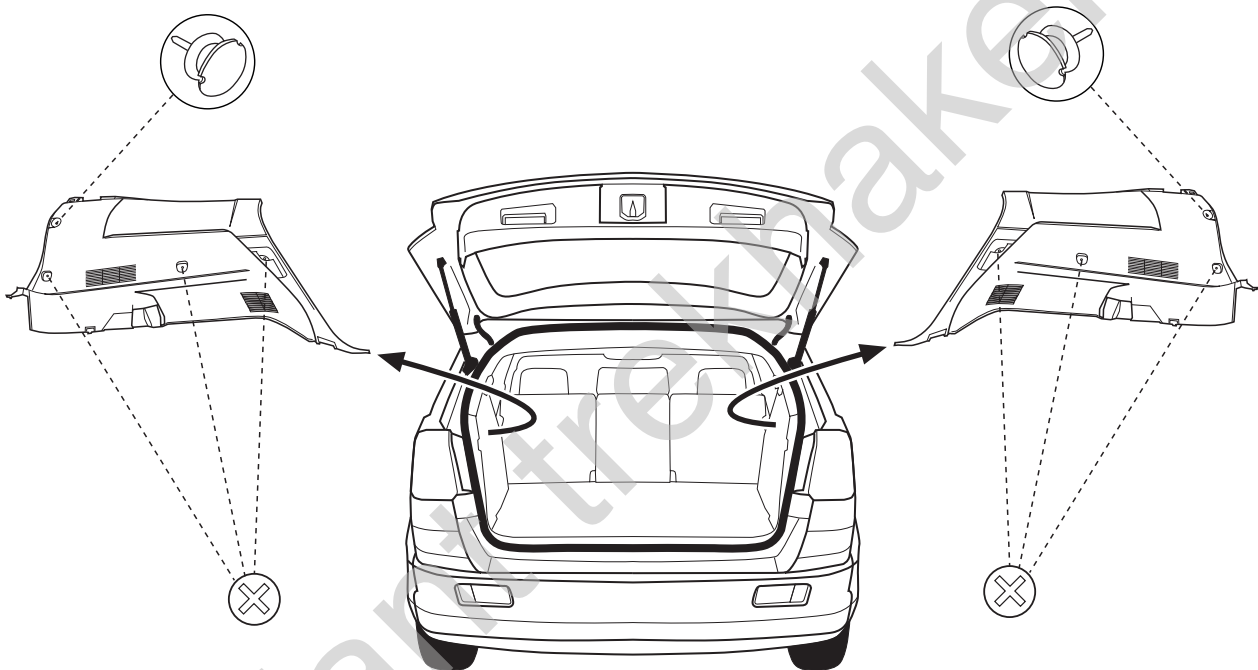
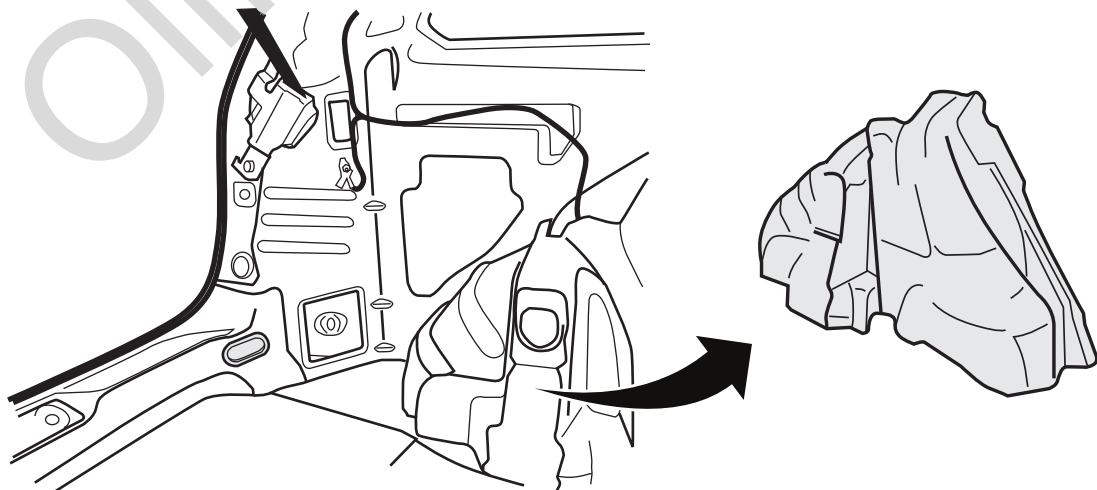
d**e****f**

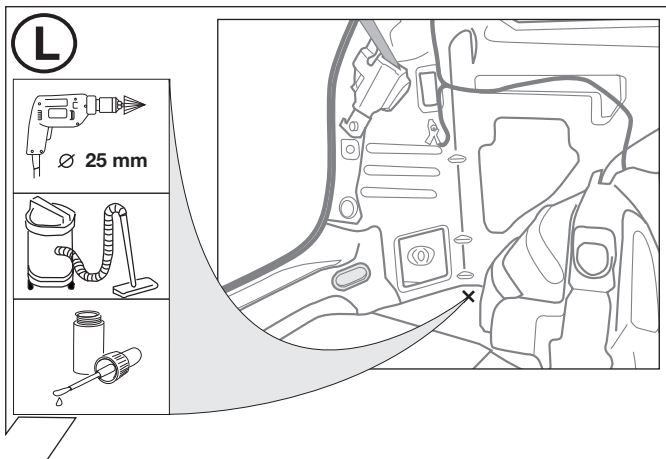

4

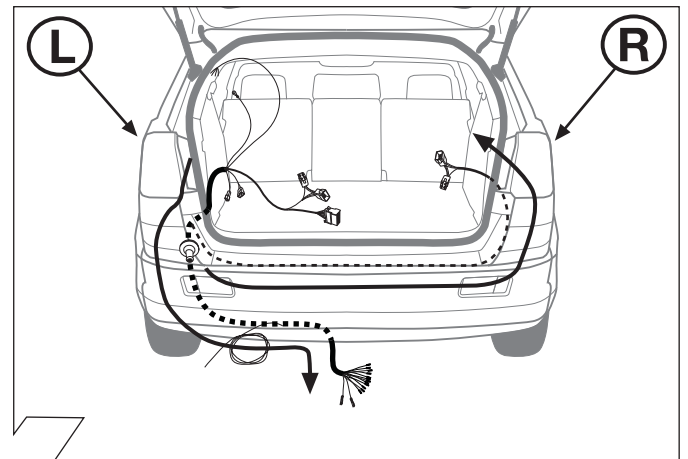

5

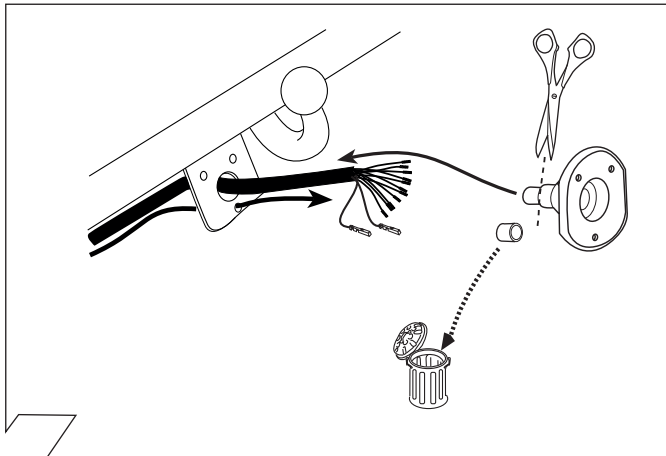

6

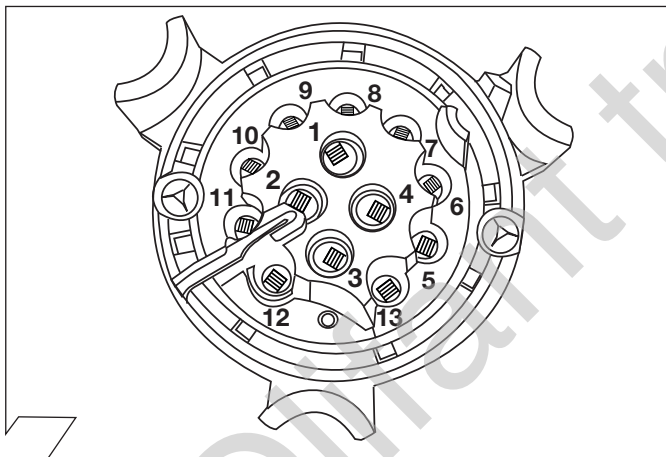

7

ISO 11446	Belegung der Steckdose / Maximale Ausgangsleistung Socket configuration / Maximum power output Correspondance des contacts de la prise / Puissance de sortie maxima Abbinamento della presa / Uscita di alimentazione massima Indeling van de stekkepoos / maximaal uitgangsvermogen		
	1/L	BK/WT	21W
	2	WT	min/max 21W
	3/31	BR	XXXX
	4/R	BK/GN	21W
	5/58-R	GY/RD	52W
	6/54	BK/RD	63W
	7/58-L	GY/BK	52W
	8	BL/RD	42W
	9	RD	240W
	10	YL	180W
	11	YL/BR	XXXX
	12	XXXX	XXXX
	13	RD/BR	XXXX

8

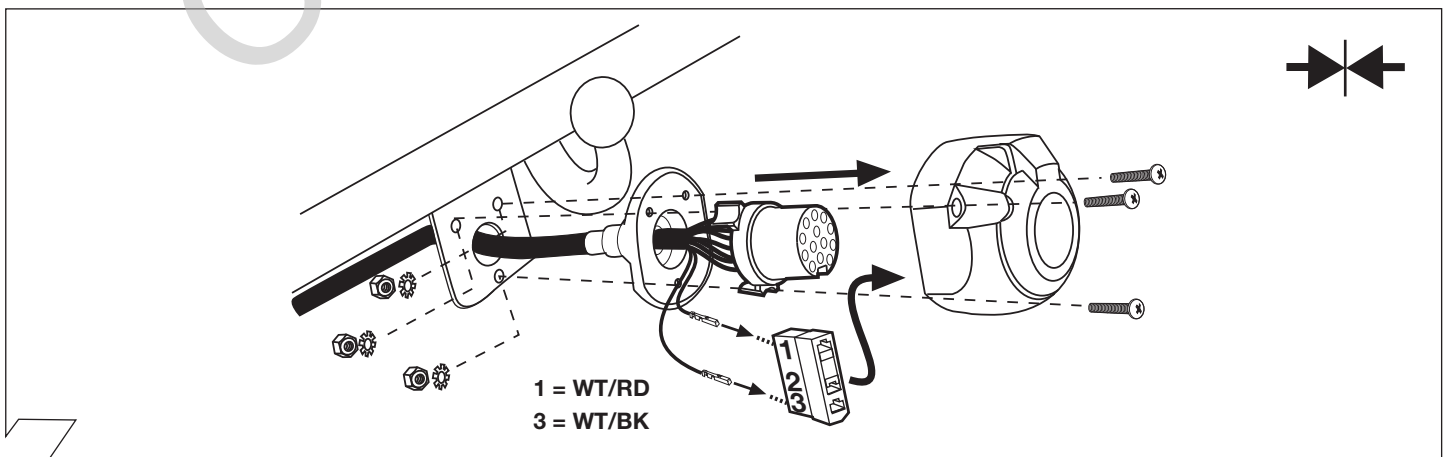

9

	(GB)	(D)	(E)	(F)	(I)	(P)	(NL)	(DK)	(N)	(S)	(FIN)	(CZ)	(H)	(PL)
BK	Black	Schwarz	Negro	Noir	Nero	Preto	Zwart	Sort	Svart	Svart	Musta	Černá	Fekete	Czarny
RD	Red	Rot	Rojo	Rouge	Rosso	Vermelho	Rood	Rød	Rød	Röd	Punainen	Červená	Piros	Czerwony
GN	Green	Grün	Verde	Vert	Verde	Verde	Groen	Grøn	Grønt	Grön	Vihreä	Zelená	Zöld	Zielony
OR	Orange	Orange	Naranja	Orange	Arancione	Laranja	Oranje	Orange	Orange	Orange	Oranssi	Oranzová	Narancs	Pomarańczowy
VT	Violet	Violett	Violeta	Violet	Viola	Violeta	Violet	Violet	Fiolett	Violett	Violetti	Fialová	Ibolya	Fioletowy
PK	Pink	Pink	Pink	Rose	Rosa	Cor-de-Rosa	Paars	Pink	Pink	Rosa	Pinkki	Růžová	Rózsaszín	Różowy
BL	Blue	Blau	Azul	Bleu	Blu	Azul	Blauw	Blå	Blått	Blå	Sininen	Modrá	Kék	Niebieski
YL	Yellow	Gelb	Amarillo	Jaune	Giallo	Amarelo	Geel	Gul	Gult	Gul	Keltainen	Zlutá	Sárga	Żółty
WT	White	Weiss	Blanco	Blanc	Bianco	Branco	Wit	Hvid	Hvitt	Vit	Valkoinen	Bílá	Fehér	Biały
BR	Brown	Braun	Marrón	Brun	Marrone	Marrom	Bruin	Brun	Brunt	Brun	Ruskea	Hnědá	Barna	Brazowy
GY	Grey	Grau	Gris	Gris	Grigio	Cinzeno	Grijs	Grå	Grått	Grå	Harmaa	Sedá	Szürke	Szary

10

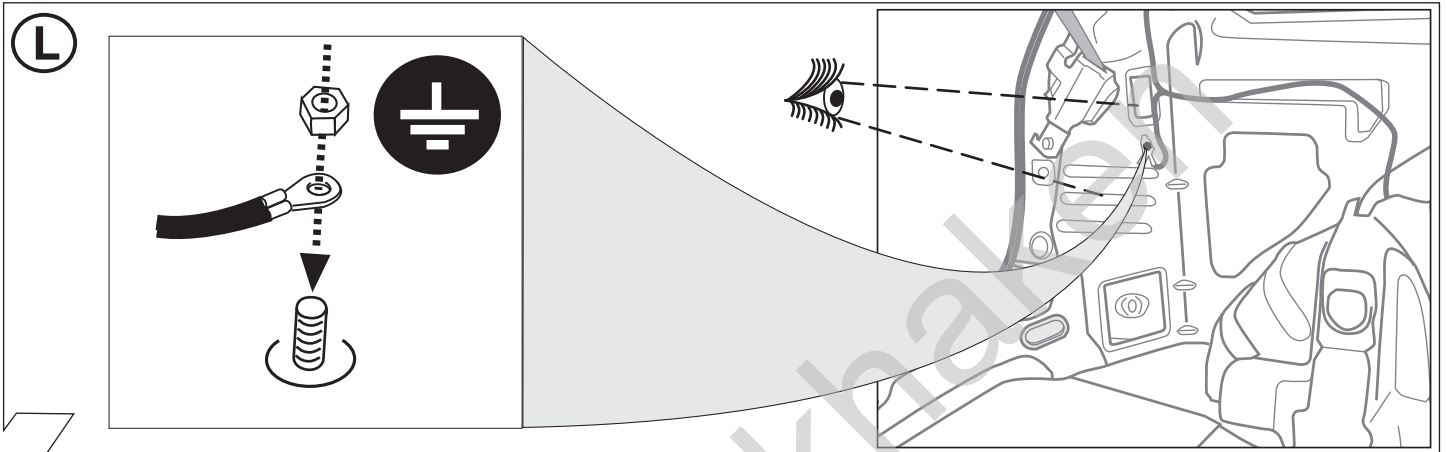

11

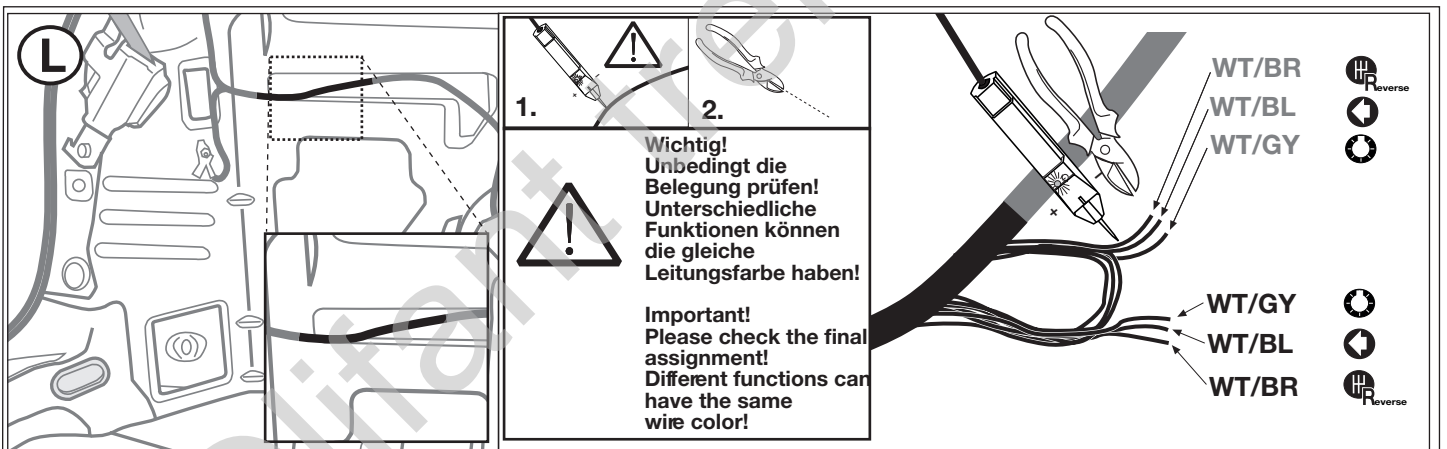

12

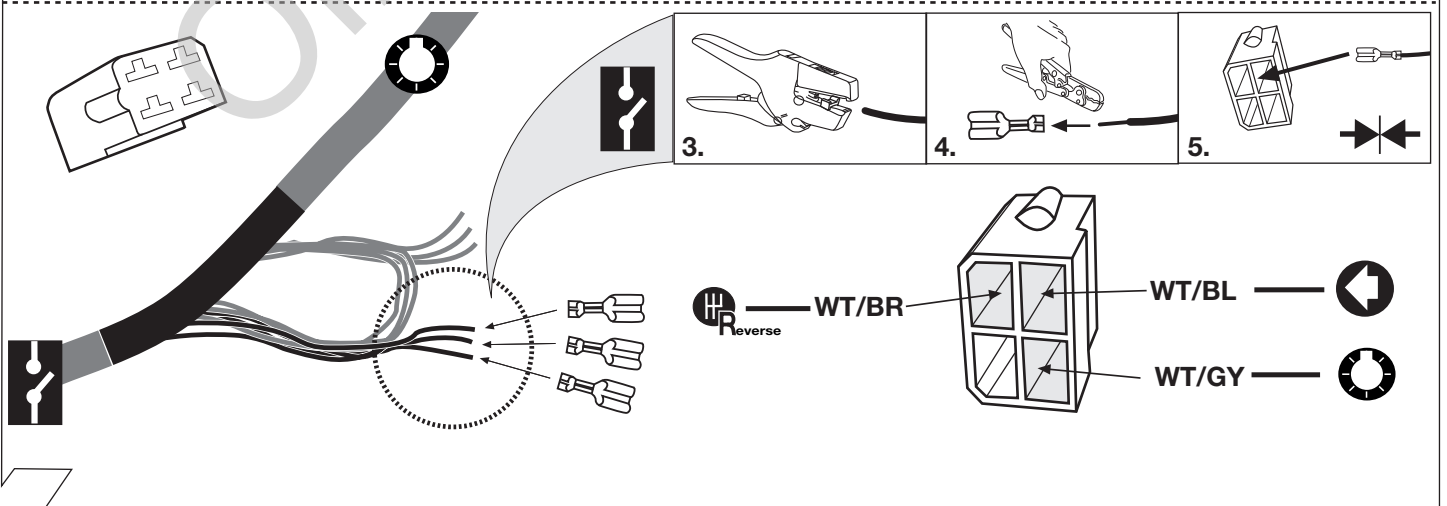

L

Wichtig!
Unbedingt die Belegung prüfen!
Unterschiedliche
Funktionen können die gleiche
Leitungsfarbe haben!

Important!
Please check the final assignment!
Different functions can have the
same wire color!

WT/BR
WT/BL
WT/GY

WT/GY
WT/BL
WT/BR

1. 2. 3.

WT/BL

WT/GY

WT/BR

13

L

14

L

WT/VT

WT/GN

L R

15

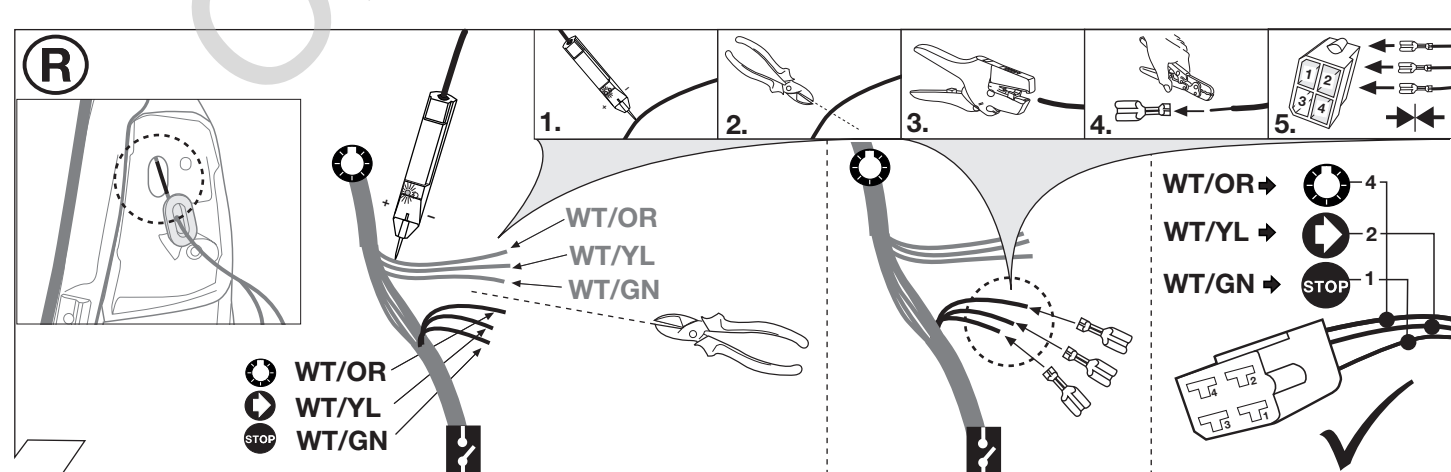
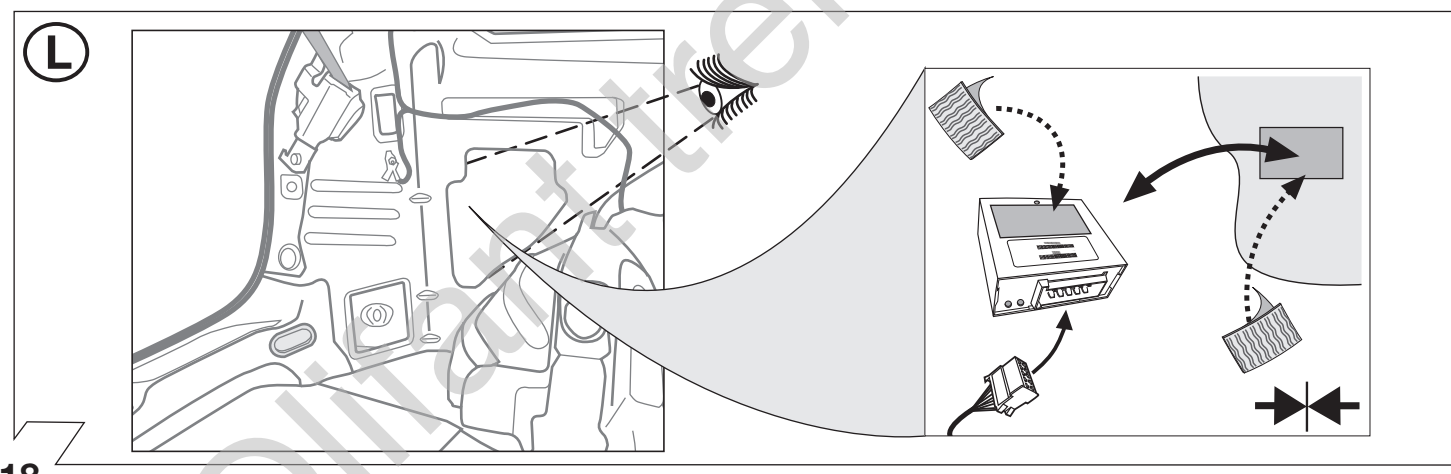
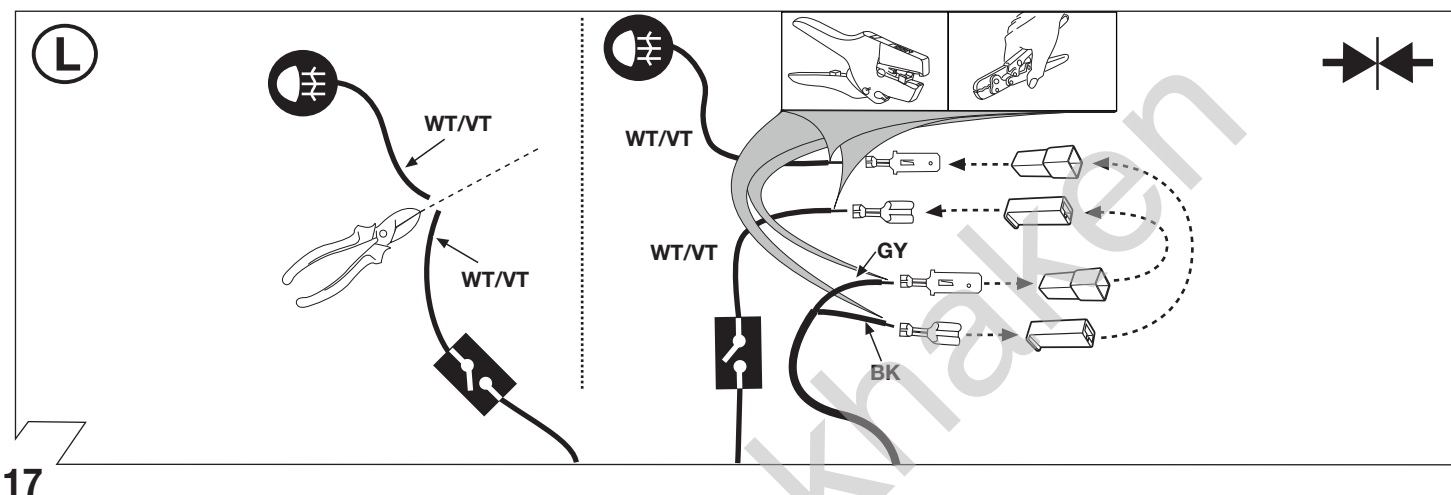
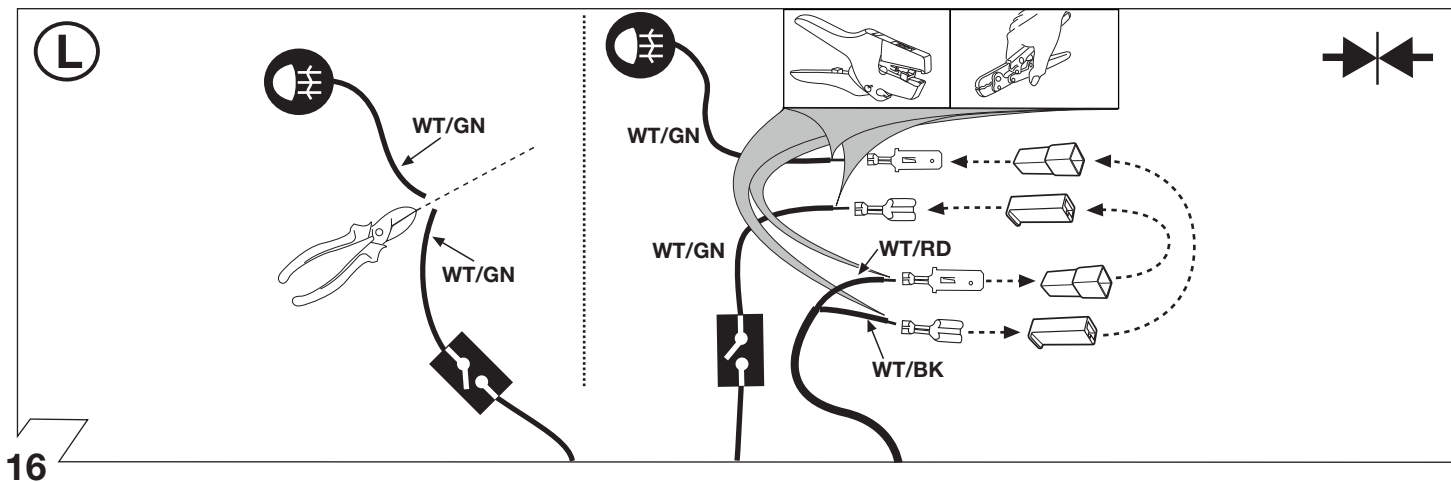

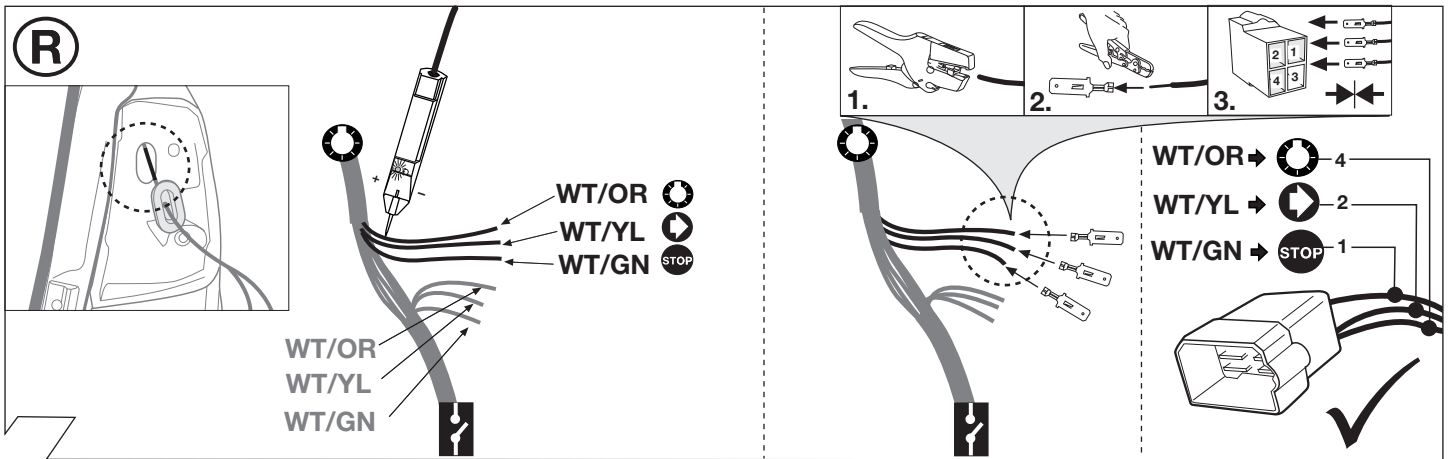

20

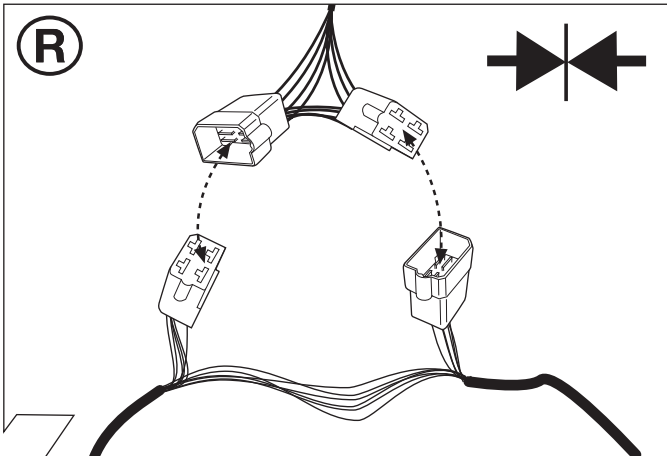

21

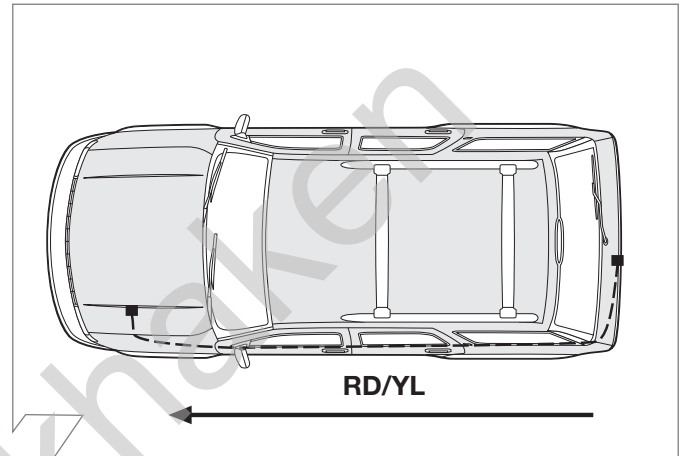

22

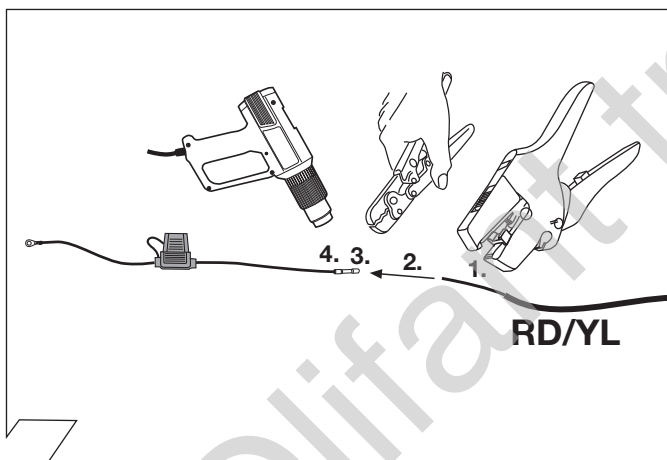

23

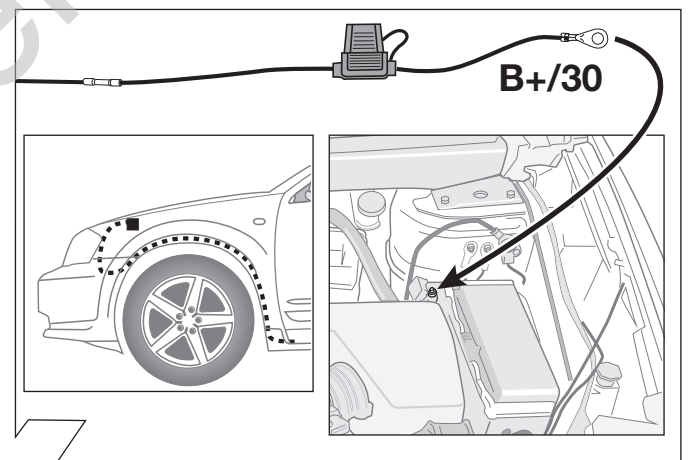

24

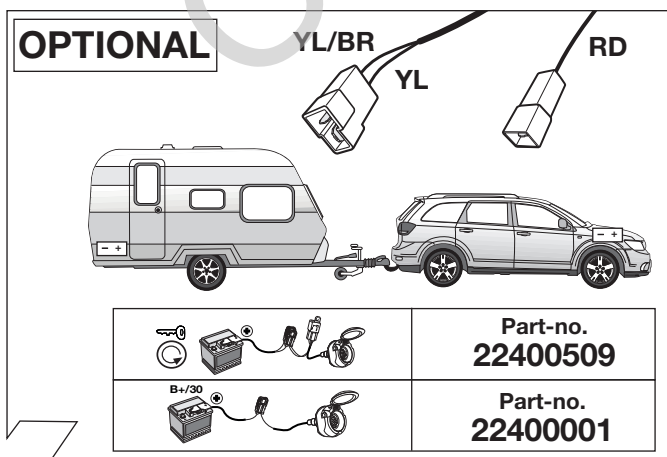

25

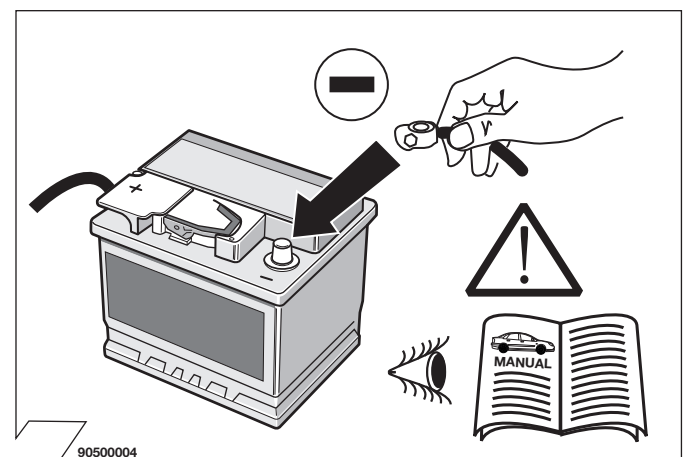

26

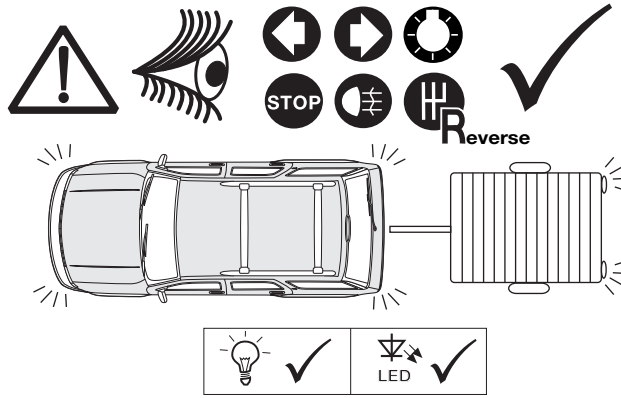

27

OPTIONAL

Trailer Simulator for 7- and 13-pin Sockets

Part-no. 50400521J

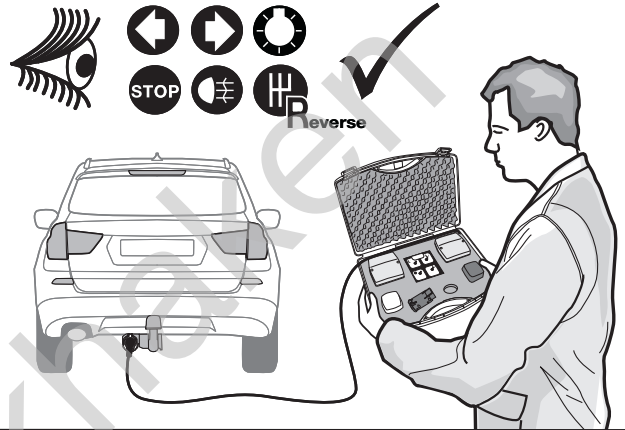

28

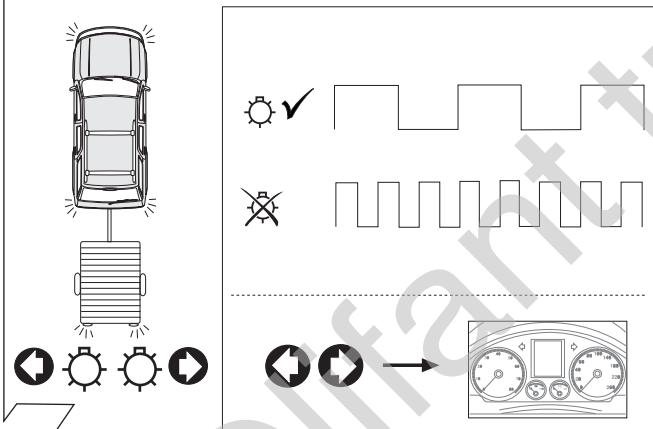

ACHTUNG: In diesem Elektro-Einbausatz ist eine Anhänger-Blinkerüberwachung (Anhänger-Modul) integriert.

Der Ausfall einer Anhänger-Blinkleuchte wird erst nach 6 bis 16 normalen Blinkintervallen mit einer doppelten Blinkfrequenz dargestellt.

Hinweis: Diese verzögerte Art der Blinkerausfallerkennung ist kein Fehler im Anhänger-Modul, sondern fahrzeugeitig bedingt! Unabhängig vom Anhängerbetrieb wird auch der Ausfall einer fahrzeugeigenen Blinkerleuchte erst leicht verzögert dargestellt!

ATTENTION:

The towing electrics now fitted to this vehicle is equipped with a trailer module which monitors the condition of the trailer flashers. If a flasher bulb on the trailer fails, there will be a delay time of between 6 and 16 normal flash cycles before a rapid flash warning is given.

NOTE: This is not a fault with the towing module, it is the vehicle's own flasher system controller which operates in this way.

29

PDC cut-off

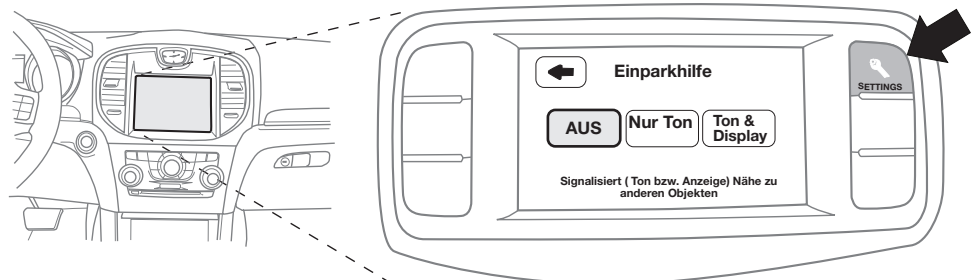

Einstellungen ➡ Sicherheit / Hilfe ➡ Einparkhilfe ➡ Aus
 Settings ➡ Safety / Help ➡ Park Distance Control ➡ Off

30

Optional: Adapter socket 62930000

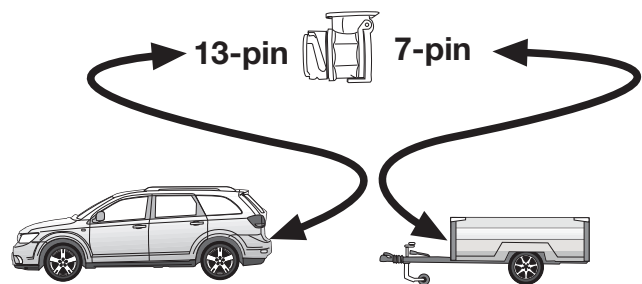

31

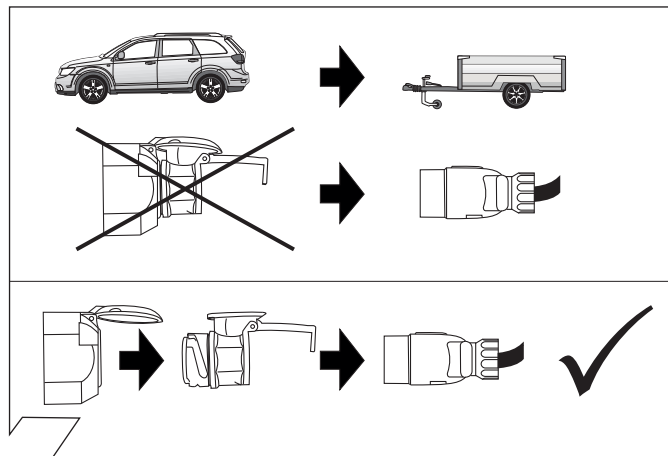

32

Olifant trekhaken

D Diagnosefunktion der Kontroll-LED's

GB Diagnosis function of control LEDs

F Fonction diagnostic des LED de contrôle

I Funzione di diagnostica dei LED di controllo

E Función de diagnóstico de los LEDs de control

NL Diagnosefunctie van de controle-LED's

