

## FITTING INSTRUCTION

Clamp mark in acc. with		Cables joining
ISO	PN	
1	L	Left directional lights
2	+	Rear fog lights
3	31	Ground
4	R	Right directional lights
5	58R	Right side parking lights
6	54	Stoptlights
7	58L	Left side parking lights

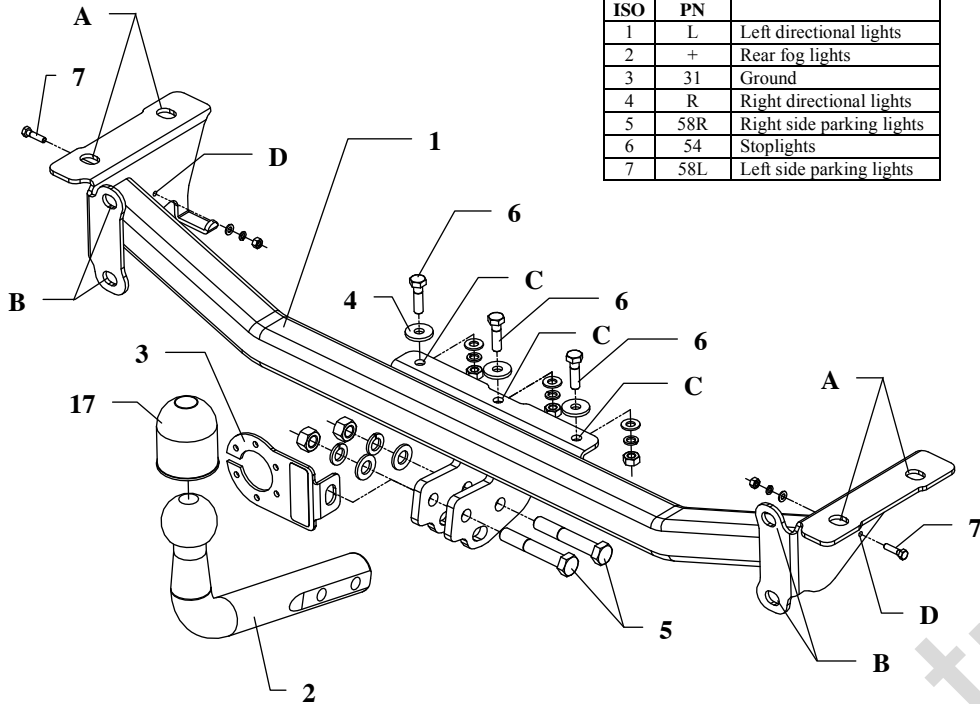

This towbar is designed to assembly in following car: **FIAT CINQUECENTO, 3 DOORS**, catalogue no. **S07**, produced since 1992 till 1998 and is prepared to tow trailers max total weight **400 kg** and max vertical load **28 kg**.

### Foreword

Thank you for buying our product. Their reliability has been confirmed in many tests. Reliability of towbar depends also on correct assembly and correct exploitation. For this reasons we kindly ask to read carefully this instruction and apply to hints.

The towbar should be install in points described by a car producer.

## The instruction of the assembly

1. From trunk take out a spare wheel and jack.
2. Pull off rubber fastener of rear muffler.
3. Unscrew handles of countermuddy covers.
4. Disassemble a bumper, next unscrew his brackets which fasten bumper to body of car.
5. From below, in places for unscrewed brackets mount main bar of towbar (pos. 1) and screw through holes pos. A using bolts remaining for original brackets (M8x35mm).
6. From below a car, through three holes pos. C drill (bit  $\varnothing 9$  mm) holes to place of spare wheel, secure using protective paint. Next put bolts M8x30mm (pos. 6) from spare wheel side with washers  $\varnothing 25 \times \varnothing 9 \times 3$ mm (pos. 4) from equipment and screw all from below a car.
7. Assemble bumper through holes pos. B
8. Fix handles of countermuddy covers at points D by bolts M5x20mm (pos. 7) from equipment.
9. Fix tow-ball (pos. 2) and socket plate (pos. 3) using bolts M12x75mm from equipment.
10. Tighten all bolts according to the torque shown in the table.
11. Connect electric wires of 7-bolts socket according to the instruction of the car. (Recommend to make at authorized service station)
12. Complete the paint coating damaged during installation.

Torque settings for nuts and bolts (8,8):

<b>M 8</b>	25 Nm	<b>M 10</b>	55 Nm
<b>M 12</b>	85 Nm	<b>M 14</b>	135Nm











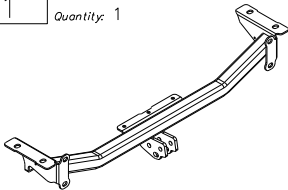

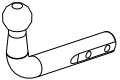

### NOTE

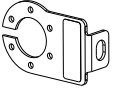
After install the towbar you should get adequate registration in registration book (at authorised service station).The car should be equipped with:

- Indicators
- Tow mirrors

After 1000km check all bolts and nuts. The ball of towbar must be always kept clear and conserve with a grease.

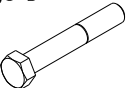
Towbar equipment:

Pos. 1 Name: Main bar Quantity: 1 	Pos. 6 Name: Bolt 8,8 B Quantity: 3 Dim.: M8x30mm 	Pos. 12 Name: Plain washer Quantity: 3 Dim.: Ø 8,4 mm 
	Pos. 7 Name: Bolt 8,8 B Quantity: 2 Dim.: M5x20mm 	Pos. 13 Name: Plain washer Quantity: 2 Dim.: Ø 5,5 mm 
Pos. 2 Name: Ball Quantity: 1 	Pos. 8 Name: Nut 8 B Quantity: 2 Dim.: M12 	Pos. 14 Name: Spring washer Quantity: 2 Dim.: Ø 12,2 mm 
Pos. 3 Name: Socket plate Quantity: 1 	Pos. 9 Name: Nut 8 B Quantity: 3 Dim.: M8 	Pos. 15 Name: Spring washer Quantity: 3 Dim.: Ø 8,3 mm 
Pos. 4 Name: Plain washer Quantity: 3 Dim.: Ø25xØ9x3 	Pos. 10 Name: Nut 8 B Quantity: 2 Dim.: M5 	Pos. 16 Name: Spring washer Quantity: 2 Dim.: Ø 5,3 mm 
Pos. 5 Name: Bolt 8,8 B Quantity: 2 Dim.: M12x75mm 	Pos. 11 Name: Plain washer Quantity: 2 Dim.: Ø 13 mm 	Pos. 17 Name: Ball cover Quantity: 1 



**PPUH AUTO-HAK S.J.**

Produkcja Haków Holowniczych  
Henryk i Zbigniew Nejman  
76-200 SŁUPSK ul. Słoneczna 16K  
tel/fax (059) 8-414-414; 8-414-413  
E-mail: [office@autohak.com.pl](mailto:office@autohak.com.pl)  
[www.autohak.com.pl](http://www.autohak.com.pl)

**Towing hitch (without electrical set)**

Class: **A50-X** Cat. no. **S 07**

Designed for:

Manufacturer: **FIAT**

Model: **CINQUECENTO**

Type: **3 doors**

produced since 1992 till 1998

**Approval number acc. to regulations EKG/ONZ 55.01: E20 55R-01 1247**

Technical data:

maximum D-value: **2,95 kN**

maximum trailer weight: **400 kg**

maximum vertical cup load: **28 kg**

**Foreword**

This towbar is design according to rules of safety traffic regulations. The towing hitch is a safety component and must be installed only by qualified personnel. Any alteration or conversion to the towinh hitch is prohibited and would lead to cancellation of design certification. Remove insulating compound and underseal from vehicle (if present) in the area of the matting surfaces of the towing hitch. The vehicle manufacturer's specifications regarding trailer load and max. vertical cup load are decisive for driving, and values for the towing hitch must not be exceeded.

D-value formula:

$$\frac{\text{Max trailer weight [kg]} \times \text{Max vehicle weight [kg]}}{\text{Max trailer weight [kg]} + \text{Max vehicle weight [kg]}} \times \frac{9,81}{1000} = D \text{ [kN]}$$