

# AUTO-HAK Sp. z o.o.

ul. Słoneczna 16K 76-200 SŁUPSK  
POLAND

tel/fax +48 59 8 414 414; +48 59 8 414 413

e-mail: [office@autohak.com.pl](mailto:office@autohak.com.pl)

[www.autohak.com.pl](http://www.autohak.com.pl)



# AUTO-HAK



**BMW 7 (F01) 4D**

⌚ 11.2008 → 02.2014

**BMW 7 (F01, F02) 4D**

⌚ 03.2014 →

Cat. no:

**B24**



E20-55R-01 4471

**D**

12,15 kN



R=2200 kg



S=100 kg



3h

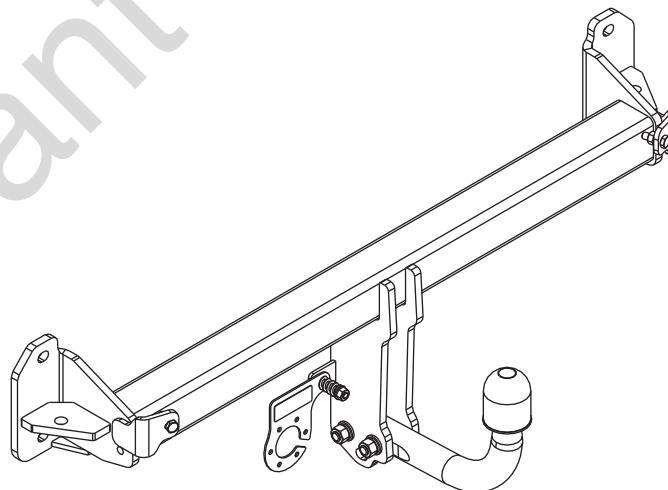

M6 - 11 Nm  
M10 - 50 Nm  
M14 - 138 Nm

M8 - 25 Nm  
M12 - 87 Nm  
M16 - 210 Nm







0 km →

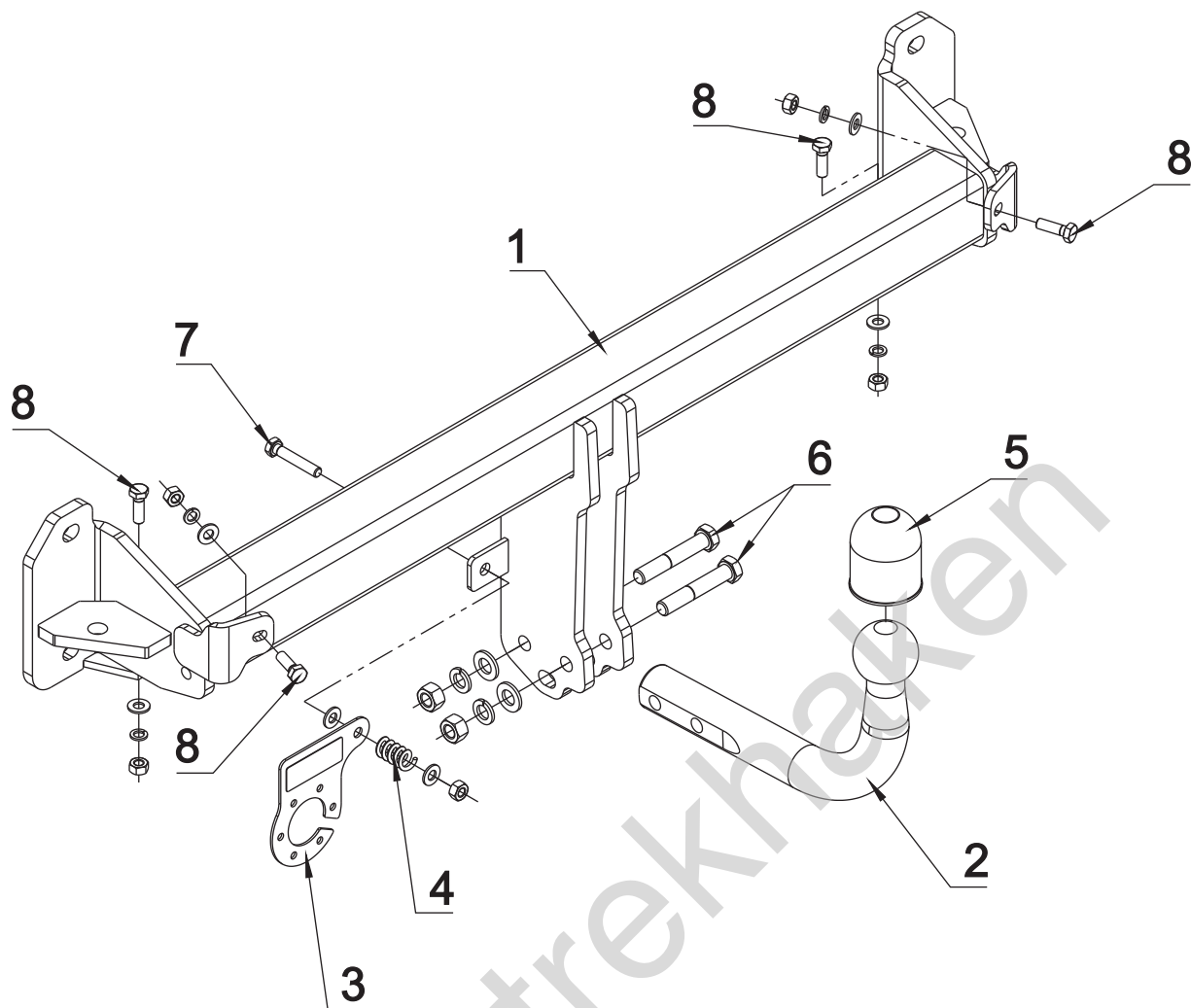

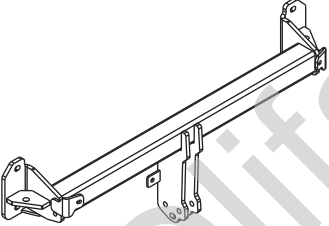
1000 km

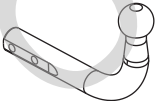

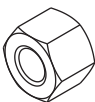
<b>1</b> 	<b>x1</b>		<b>6</b> M12x70	<b>x2</b>
			<b>7</b> M8x45	<b>x1</b>
			<b>8</b> M8x25	<b>x4</b>
			<b>9</b> $\varnothing$ 13	<b>x2</b>
			<b>10</b> $\varnothing$ 8.4	<b>x6</b>
			<b>11</b> $\varnothing$ 12.2	<b>x2</b>
<b>2</b> 	<b>x1</b> Art.nr-KL1B24		<b>12</b> $\varnothing$ 8.2	<b>x4</b>
			<b>13</b> M12	<b>x2</b>
<b>3</b> 	<b>x1</b> Art.nr-BL1B24		<b>14</b> M8	<b>x5</b>
			<b>4</b>	<b>x1</b>
<b>5</b>	<b>x1</b>			

01

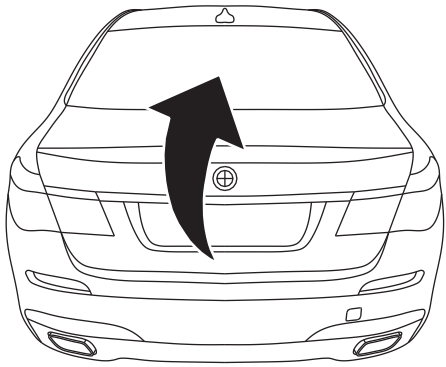

02

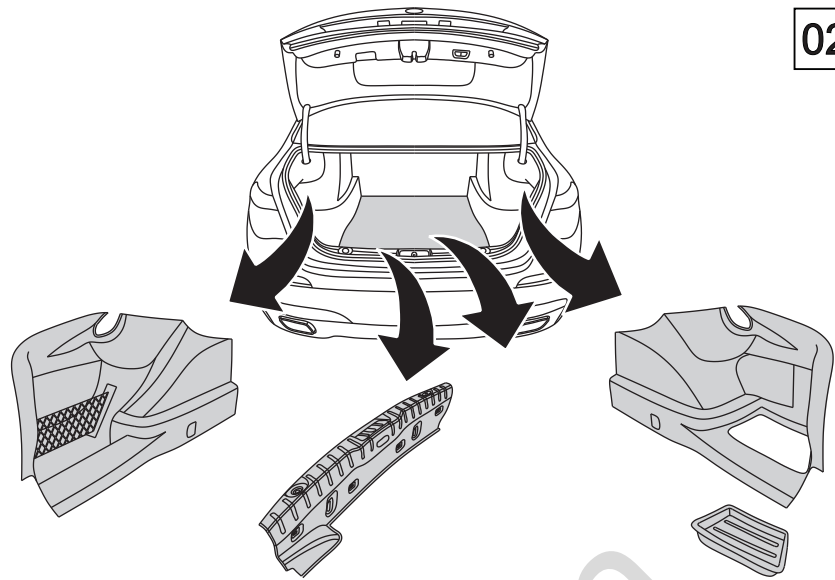

03

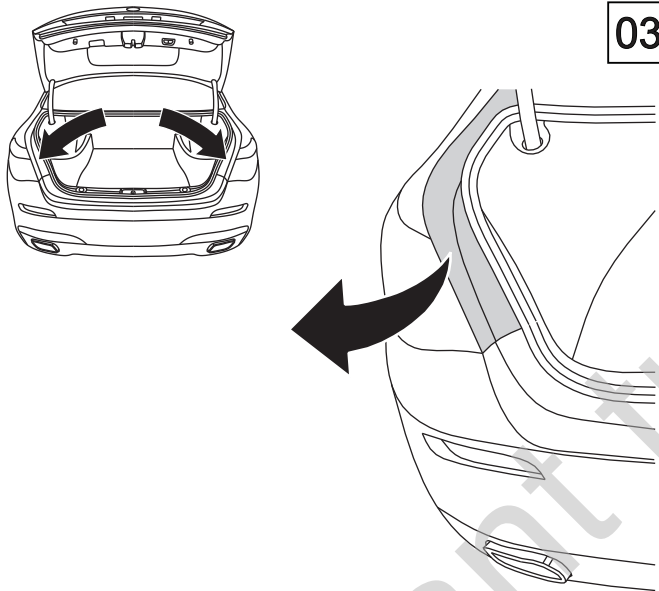

04

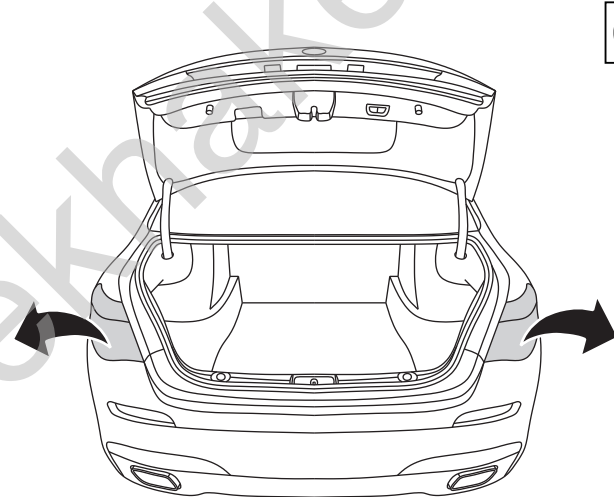

05

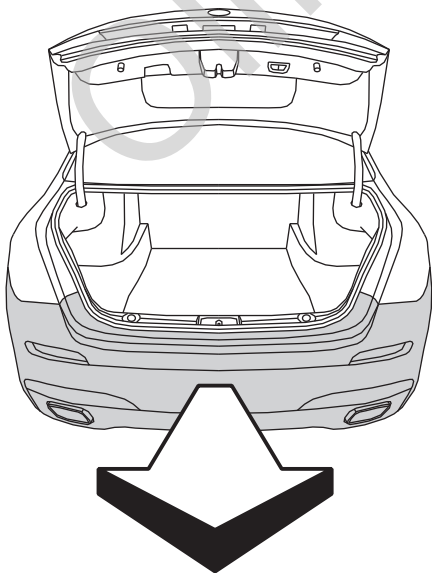

06

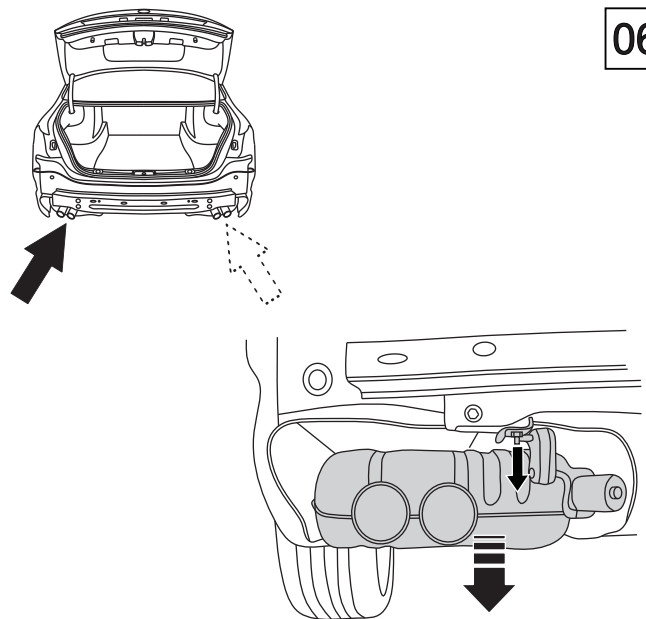

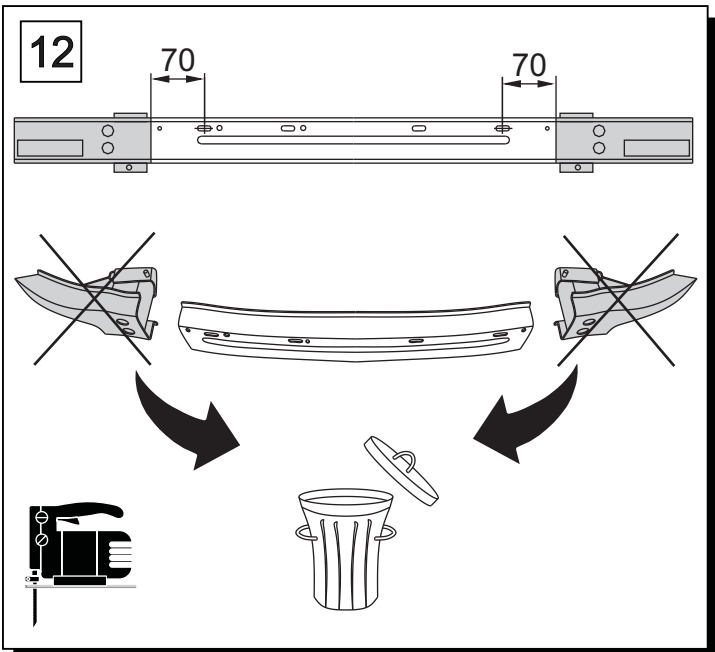
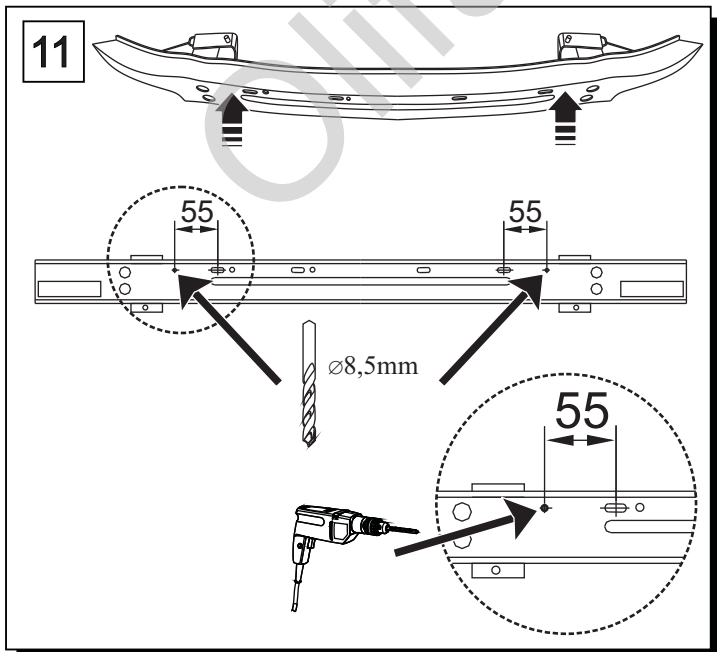
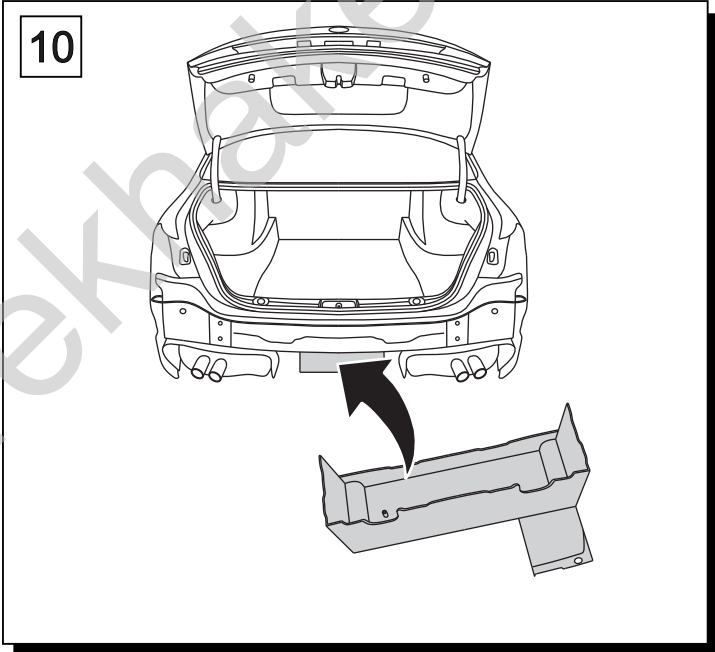
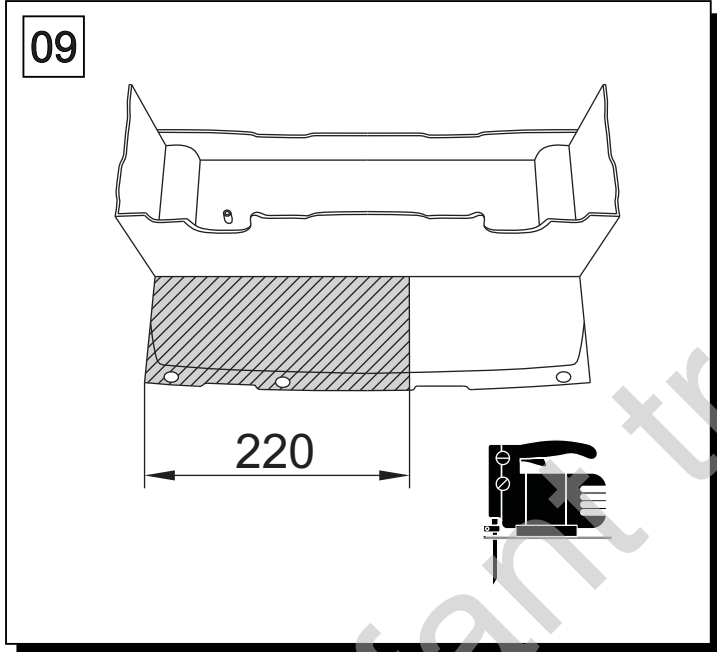
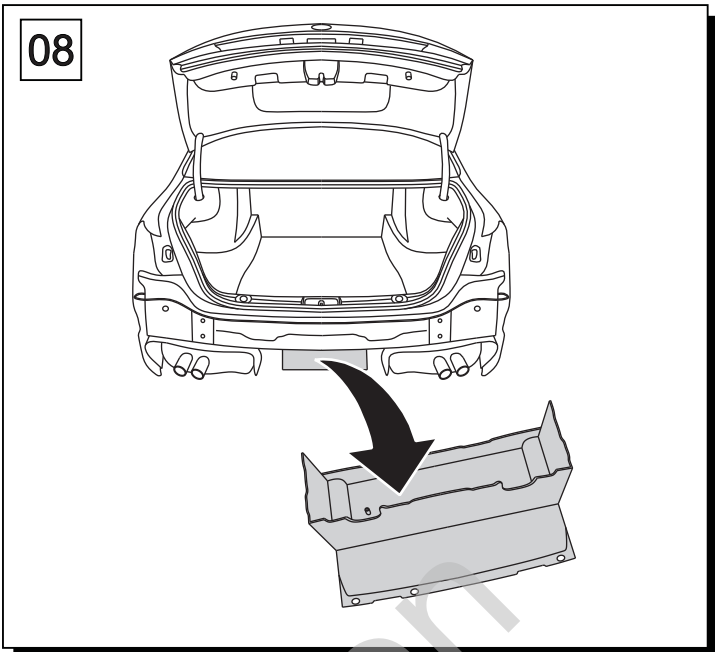
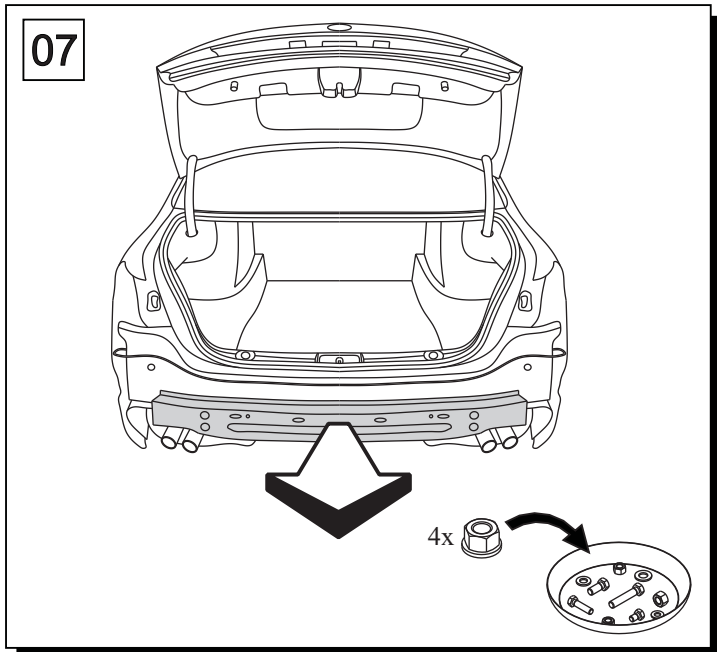

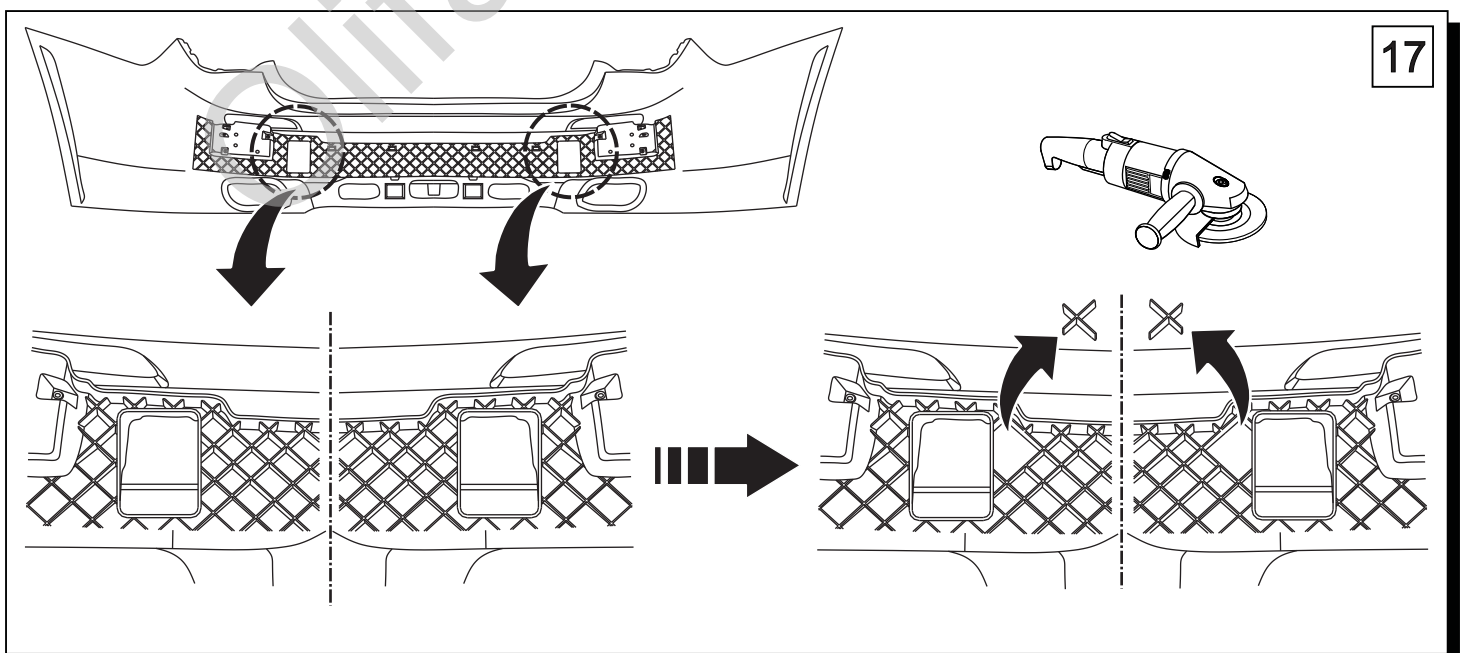
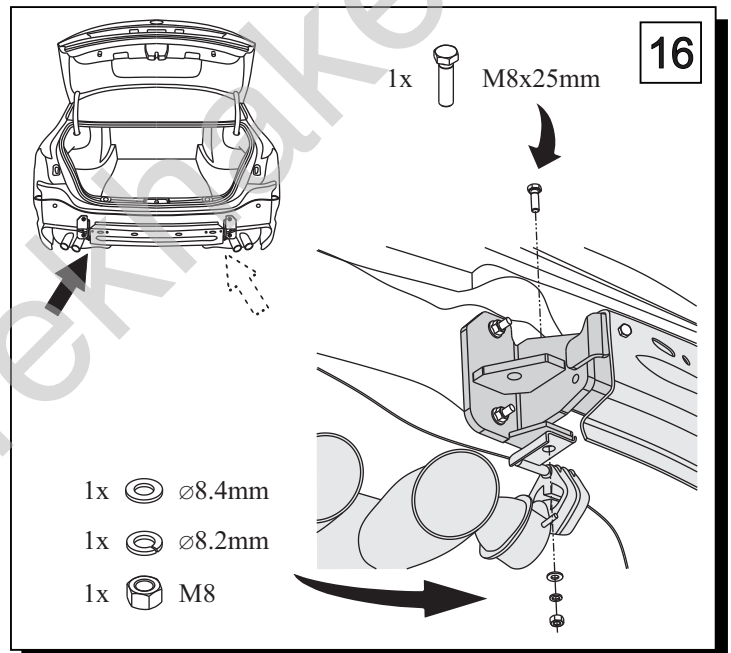
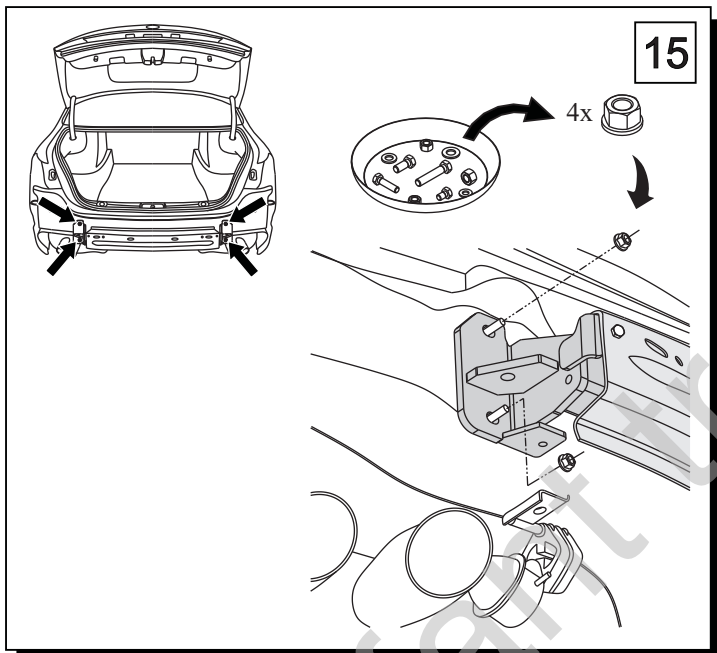
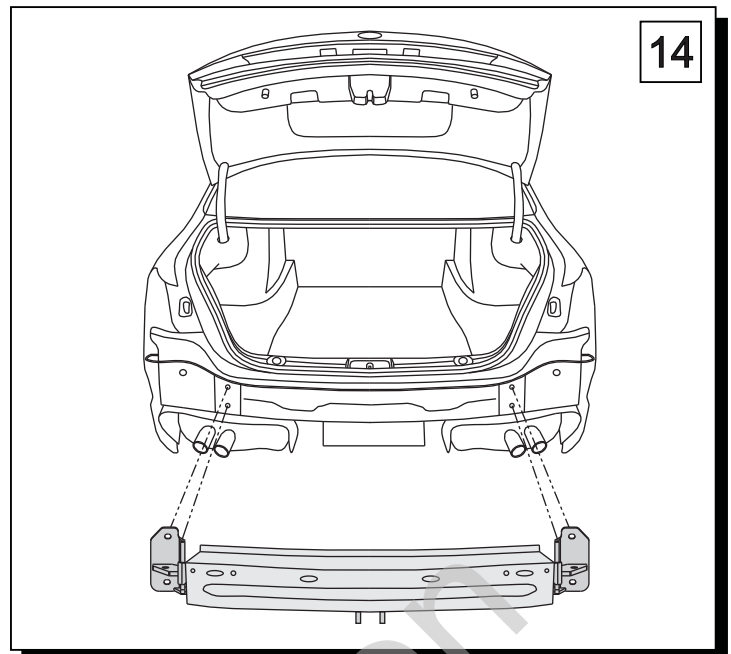
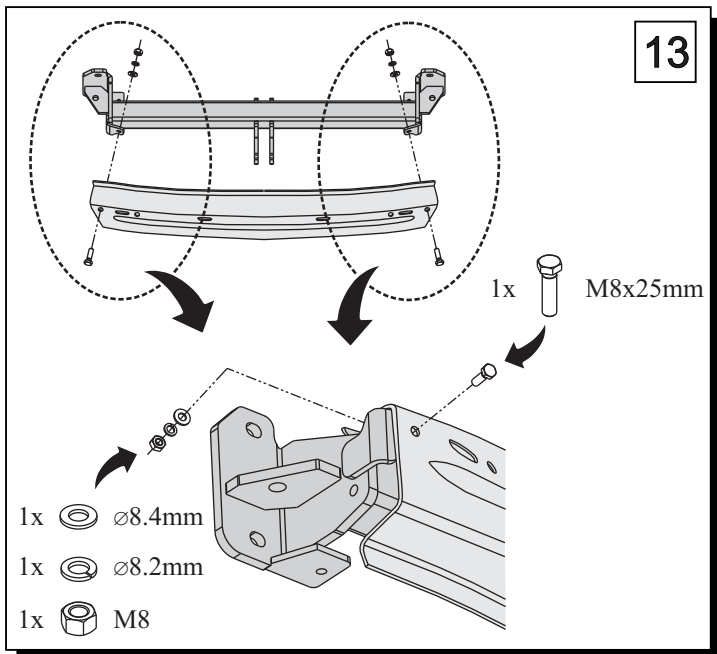

18

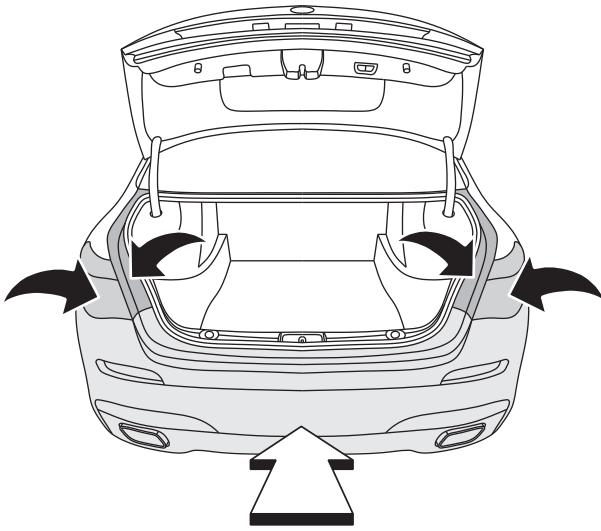

19

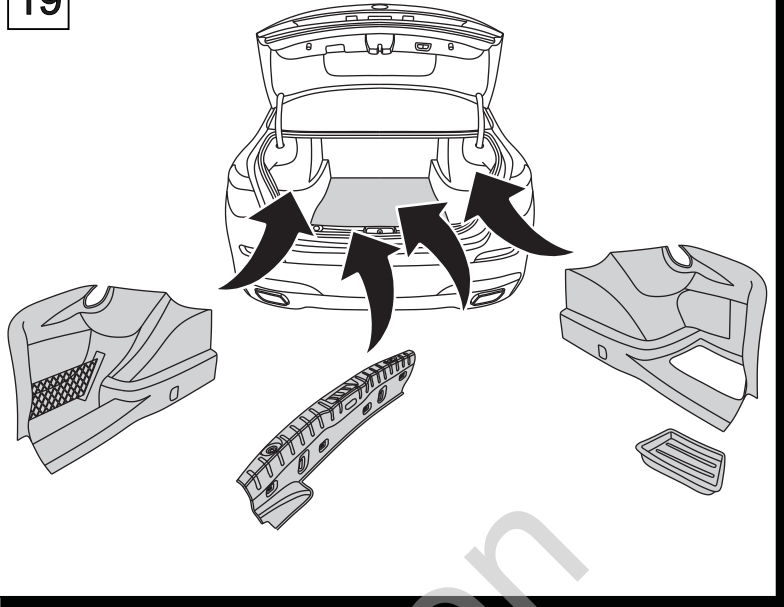

20

